

RULES FOR
CLASSIFICATION OF

SHIPS

SHIPS IN OPERATION

PART 7 CHAPTER 1

GENERAL REQUIREMENTS

JANUARY 2003

CONTENTS		PAGE
Sec. 1	General	5
Sec. 2	Classification Certificate, Periodical Surveys and Intervals	6
Sec. 3	General Requirements for Hull and Machinery Surveys	14
Sec. 4	Requirements for Enhanced Survey Program (ESP)	16
Sec. 5	Alternative Survey Arrangements and Surveys Performed by Approved Companies.....	17
Sec. 6	Retroactive Rule Requirements	20

DET NORSKE VERITAS

Veritasveien 1, N-1322 Høvik, Norway Tel.: +47 67 57 99 00 Fax: +47 67 57 99 11

CHANGES IN THE RULES

General

The present edition of the rules includes additions and amendments decided by the board as of December 2002, and supersedes the July 2002 edition of the same chapter.

The rule changes come into force on 1 July 2003.

This chapter is valid until superseded by a revised chapter. Supplements will not be issued except for an updated list of minor amendments and corrections presented in Pt.0 Ch.1 Sec.3. Pt.0 Ch.1 is normally revised in January and July each year.

Revised chapters will be forwarded to all subscribers to the rules. Buyers of reprints are advised to check the updated list of rule chapters printed in Pt.0 Ch.1 Sec.1 to ensure that the chapter is current.

Main changes

• Section 1 – General

Amendments related to the removal of Total Safety Class Regulations from the rules.

- Table A2 has been amended as follows:
 - The rows concerning Ch.3, Ch.4 and Ch.6 have been deleted

• Section 2 – Classification Certificate, Periodical Surveys and Intervals

- Item B604, concerning bottom surveys, has been deleted and replaced with new text.
- Table B2 has had three new rows added concerning hull survey intervals and time windows.
- The new class notation **Tanker for Compressed Natural Gas** has been added to Table B3
- The new class notation **FUEL** has been added to Table B4
- Table B5 has been amended to include a new row called “Machinery CM Renewal”.

• Section 3 – General Requirements for Hull and Machinery Surveys

- Item C101 has been amended to include machinery systems and equipment, with a new reference to Pt.7 Ch.8 Sec.1 Table A1.

- A Guidance note has been added to C401 concerning significant and insignificant repairs.

• Section 5 – Alternative survey arrangements and Surveys Performed by Approved Companies

- In A100 the title “General” has been amended to read: “General overview of survey arrangements”
- The new class notation **Tanker for Compressed Natural Gas** has been added to A301.

• Section 6 – Retroactive Rule Requirements

- Sub-section A. Bow doors, has been deleted.
- Sub-section B. Side shell doors and stern doors, has been deleted.
- Sub-section C. Increased stability and watertight integrity of existing passenger ships engaged on international voyages, has been deleted.
- Sub-section D. Tankers, has been deleted.
- In sub-sections elements E100 and F100, the implementation of IACS URs: S19, S22 and S23 has been brought forward to the 10 year anniversary date (from 15 Years). The text in E101 and F101 has been amended accordingly.
- In sub-sections elements E100 and F100, all instances of “first complete periodical survey” have been amended to read. “first renewal survey”.
- Sub-section E has been amended to read: sub-section A.
- Sub-section F has been amended to read: sub-section B.
- Sub-section G has been amended to read: sub-section C.
- Sub-section H has been amended to read: sub-section D.
- Sub-section I. Safety of navigation, has been deleted.
- Sub-section J. periodically unattended machinery space and machinery centralised operated, has been deleted.
- Sub-section K has been amended to read: sub-section E.
- Sub-section L has been amended to read: sub-section F.

Corrections and Clarifications

In addition to the above stated rule requirements, a number of detected errors, corrections and clarifications have been made in the existing rule text.

Comments to the rules may be sent by e-mail to rules@dnv.com

For subscription orders or information about subscription terms, please use distribution@dnv.com

Comprehensive information about DNV and the Society's services is found at the Web site <http://www.dnv.com>

© Det Norske Veritas

Computer Typesetting (FM+SGML) by Det Norske Veritas

Printed in Norway

If any person suffers loss or damage which is proved to have been caused by any negligent act or omission of Det Norske Veritas, then Det Norske Veritas shall pay compensation to such person for his proved direct loss or damage. However, the compensation shall not exceed an amount equal to ten times the fee charged for the service in question, provided that the maximum compensation shall never exceed USD 2 million.
In this provision “Det Norske Veritas” shall mean the Foundation Det Norske Veritas as well as all its subsidiaries, directors, officers, employees, agents and any other acting on behalf of Det Norske Veritas.

CONTENTS

<p>SEC. 1 GENERAL 5</p> <p>A. Definitions and Scope.....5</p> <p>A 100 Definitions.....5</p> <p>A 200 Scope of rules for ships in operation.....5</p> <p>SEC. 2 CLASSIFICATION CERTIFICATE, PERIODICAL SURVEYS AND INTERVALS 6</p> <p>A. Periodical Surveys.....6</p> <p>A 100 General.....6</p> <p>B. Periodical Surveys and Intervals6</p> <p>B 100 General.....6</p> <p>B 200 Annual survey, main and mandatory class notations.....6</p> <p>B 300 Intermediate survey, main and mandatory class notations6</p> <p>B 400 Renewal survey, main and mandatory class notations.....6</p> <p>B 500 Other periodical surveys6</p> <p>B 600 Survey intervals and concurrent surveys6</p> <p>B 700 Postponement of periodical surveys12</p> <p>B 800 Survey of ships out of commission12</p> <p>C. Classification Certificate12</p> <p>C 100 Certificate endorsement12</p> <p>C 200 Validity of the Classification Certificate13</p> <p>C 300 Issue of Classification Certificate and expiry date.....13</p> <p>SEC. 3 GENERAL REQUIREMENTS FOR HULL AND MACHINERY SURVEYS..... 14</p> <p>A. General.....14</p> <p>A 100 Surveyor's safety14</p> <p>B. Requirements for Hull Surveys14</p> <p>B 100 Conditions for survey and access to structures14</p> <p>B 200 Thickness measurements, hull structures.....14</p> <p>B 300 Repair of structural damage or deterioration14</p> <p>C. Requirements for Machinery Surveys14</p> <p>C 100 Maintenance system.....14</p> <p>C 200 Shaft alignment14</p> <p>C 300 Replacement of machinery components15</p> <p>C 400 Machinery verification15</p> <p>SEC. 4 REQUIREMENTS FOR ENHANCED SURVEY PROGRAM (ESP)..... 16</p> <p>A. General.....16</p> <p>A 100 Application.....16</p> <p>A 200 Survey programme.....16</p> <p>A 300 Documentation on board.....16</p>	<p>SEC. 5 ALTERNATIVE SURVEY ARRANGEMENTS AND SURVEYS PERFORMED BY APPROVED COMPANIES..... 17</p> <p>A. Alternative Survey Arrangements..... 17</p> <p>A 100 General overview of survey arrangements17</p> <p>A 200 Continuous surveys, general17</p> <p>A 300 Continuous hull survey17</p> <p>A 400 Integrated survey programme (ISP), hull structures and equipment.....17</p> <p>B. Surveys by Approved Companies or Service Suppliers . 18</p> <p>B 100 General18</p> <p>B 200 Thickness measurements18</p> <p>B 300 Examination of ro-ro ships' bow, side and stern doors ...18</p> <p>B 400 Bottom survey afloat.....19</p> <p>SEC. 6 RETROACTIVE RULE REQUIREMENTS . 20</p> <p>A. Existing Bulk Carriers - Corrugated Transverse Watertight Bulkheads considering Cargo Hold Flooding 20</p> <p>A 100 Application and definition20</p> <p>A 200 Load model20</p> <p>A 300 Strength criteria.....23</p> <p>A 400 Local details25</p> <p>A 500 Corrosion addition and steel renewal.....25</p> <p>B. Existing Bulk Carriers - Limit to Hold Loading considering Hold Flooding 26</p> <p>B 100 Application and definition26</p> <p>B 200 Load model26</p> <p>B 300 Shear capacity27</p> <p>B 400 Limit to cargo hold loading, considering flooding28</p> <p>C. Existing Bulk Carriers - Damage Stability 29</p> <p>C 100 Application.....29</p> <p>D. Existing Bulk Carriers - Loading Information 29</p> <p>D 100 Loading computer system.....29</p> <p>D 200 Loading sequences29</p> <p>E. Existing Bulk Carriers – Detection of Water Ingress into Cargo Holds 29</p> <p>E 100 Application and definition29</p> <p>E 200 Detection of water ingress29</p> <p>E 300 Means of water ingress detection.....30</p> <p>E 400 Installation, testing and survey30</p> <p>F. Existing Ice Class ICE-1A and ICE-1A* - Minimum Power Requirement 30</p> <p>F 100 General30</p> <p>F 200 Application.....30</p> <p>F 300 Existing ships.....30</p>
--	--

SECTION 1 GENERAL

A. Definitions and Scope

A 100 Definitions

101 For definition of general terms used in the rules see Pt.0 Ch.2 and Pt.1 Ch.1. Additional definitions used in this chapter are given in Table A1.

Table A1 Definitions	
<i>Term</i>	<i>Definition</i>
<i>Convention ship</i>	a ship for which requirements in the international conventions ICLL, SOLAS or MARPOL apply
<i>Statutory survey</i>	survey carried out by or on behalf of a flag administration
<i>Passenger ship</i>	a ship which carries more than twelve passengers
<i>Passenger</i>	every person other than: <ul style="list-style-type: none"> — the master and the members of the crew or other persons employed or engaged in any capacity on board a ship on the business of that ship; and — a child under one year of age
<i>Cargo ship</i>	any ship which is not a passenger ship

A 200 Scope of rules for ships in operation

201 The scope of the rules in Pt.7 identifies the requirements applicable for ships in operation, as given in Table A2.

Table A2 Content of Pt.7	
<i>Chapter</i>	<i>Content</i>
Ch.1 General Survey Requirements	General requirements related to classification certificate and periodical surveys including alternative survey arrangements. Comprise the general requirements, survey types and intervals related to main class and additional class notations in order to retain class.
Ch.2 Periodical Survey Requirements	Comprise a description of the survey requirements, grouped according to the applicable periodical survey.
Ch.5 Management of Safety and Environmental Protection (SEP)	Comprise an optional system for certification of company and shipboard management based on the principles for quality management laid down by the ISO 9000 series and the ISM Code.
Ch.7 Additional Class Notation NAUTICUS	Comprise general provisions governing the assignment of the NAUTICUS class notations, with appropriate additional notations, as stated in Pt.1 Ch.1 Sec.2 B1000.
Ch.8 Machinery Survey Arrangements	Comprise the requirements for alternative survey arrangements for machinery.

202 Valid statutory certificates and compliance with the applicable international IMO conventions are conditions for maintenance of class for ships in operation, see Pt. 1 Ch. 1 Sec. 1 B400. The society reserves the right to verify that applicable convention requirements are complied with.

SECTION 2

CLASSIFICATION CERTIFICATE, PERIODICAL SURVEYS AND INTERVALS

A. Periodical Surveys

A 100 General

101 All ships shall be subjected to periodical surveys. The surveys shall be carried out at prescribed intervals. The surveys may be commenced and progressed within the given time windows with a view to complete these surveys by the end of the given range dates.

102 The surveys are to be carried out in accordance with the referred rules in order to confirm that the hull structure, machinery installations and equipment comply with applicable requirements, and will remain in satisfactory condition provided the assumptions stated in Pt.1 Ch.1 Sec.1 B400 are adhered to.

103 In cases where the administration of the flag state has given dispensation from any requirements in the international conventions as amended, DNV may upon its own discretion accept their decisions as basis for retention of class.

B. Periodical Surveys and Intervals

B 100 General

101 Periodical surveys belong to one of the categories as defined in 200 to 500. The extent of surveys is given in Ch.2.

B 200 Annual survey, main and mandatory class notations

201 Annual survey is a general survey of the hull structure, machinery installations and equipment, to confirm that the ship complies with the relevant rule requirements and is in satisfactorily maintained condition.

B 300 Intermediate survey, main and mandatory class notations

301 Intermediate survey is a survey of the hull structure, machinery installations and equipment. It shall include visual examinations, measurements and test as applicable, in order to confirm that the ship complies with the relevant rule requirements and is in satisfactorily maintained condition.

B 400 Renewal survey, main and mandatory class notations

401 Renewal survey is a major survey of the hull structure, machinery installations and equipment. Renewal surveys shall include visual examinations, measurements and tests in order to confirm that the ship complies with the relevant rule requirements and is in satisfactorily maintained condition.

402 Possible repairs shall normally be carried out before the renewal survey is regarded as completed.

DNV may accept that minor deficiencies, recorded as condition of class, are rectified within a specified time limit, normally not exceeding 3 months after the survey completion date.

B 500 Other periodical surveys

501 In addition to the surveys for main and mandatory class notations, as defined in 200 to 400, the following periodical surveys as applicable shall be carried out in order to retain class:

- bottom survey
- tailshaft survey
- survey of thrusters for propulsion
- survey of boilers
- survey of thermal oil heaters
- survey of steam heated steam generator
- survey of [voluntary] additional class notations.

502 The additional class notation's requirements shall be adhered to by the owner as conditions for the retention of these class notations, as applicable.

503 The surveys may be performed as annual surveys, intermediate surveys and or complete periodical surveys, as detailed in 600.

504 A complete periodical survey is a major survey related to an additional class notation, system or component.

505 Alternative survey arrangements may be accepted as an option to the applicable periodical surveys for main class, see Sec.5.

B 600 Survey intervals and concurrent surveys

601 The due date of a periodical survey will be established depending upon the survey interval, measured from one of the following events, whichever is relevant:

- date of class assignment
- date of commissioning
- due date of the previous corresponding survey
- date of completion of the previous corresponding survey
- date of completion of a major conversion, see C305.

Survey intervals should in general be as given in Table B1. The detailed intervals are given in Table B2 to Table B5.

Intervals may be reduced at owner's request i.e. the survey may be carried out prior to the defined time window. In such a case the survey's anniversary date will be adjusted accordingly.

Table B1 Survey intervals				
Survey type	Interval (years)	Time window (months) see Fig.1		Remarks
		W_B	W_A	
Annual survey	1	3	3	
Intermediate survey	5	9	9	First time 2.5 years after delivery.
Complete periodical survey, 2.5 year	2.5	6	6	
Complete periodical survey, 5 year	5	3	3	
Renewal survey, 5 year	5	3	0	

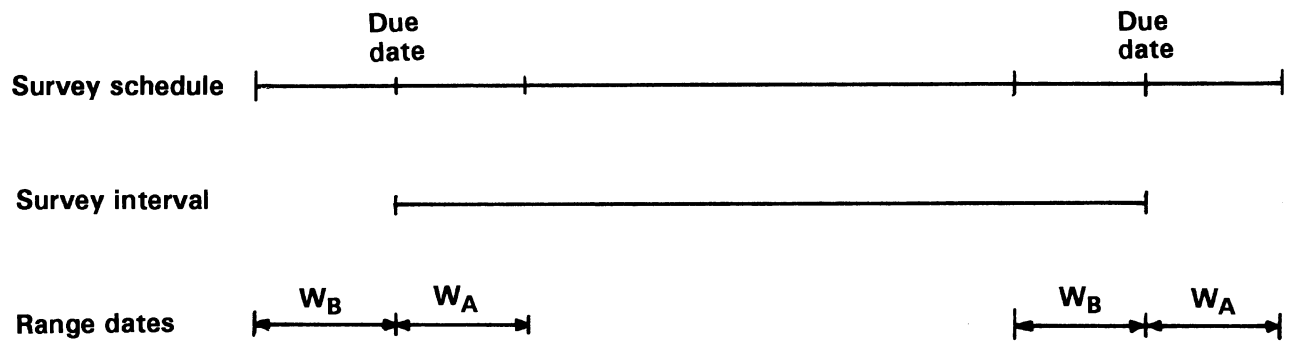

Fig. 1
Survey time windows

602 For certain ships the survey intervals may be reduced by the administration, see C200.

603 Main class intermediate survey, if applicable, including mandatory class notations, shall have a due date midway in the certificate period with a time window of +/-9 months. However, the survey shall be completed concurrently with the second or third annual survey main class. The survey may be commenced at second annual survey or between second and third annual survey.

604 Bottom surveys are surveys of the outside of the ship's hull below the deepest load waterline and related items. The bottom survey intervals are in general to satisfy the following conditions:

- Two bottom surveys are required during each five-year period of the classification certificate.
- The interval between any two successive bottom surveys is in no case to exceed 36 months.
- One such survey is to be carried out not more than 15 months prior to the expiry date of the classification certificate, in conjunction with the renewal survey.

For passenger ships the bottom survey intervals are to satisfy the following conditions:

- Bottom surveys are required on an annual basis.
- The interval between any two successive bottom surveys is in no case to exceed 15 months.

For ships operating in fresh water and for certain harbour or non-self-propelled craft bottom survey intervals greater than that given above may be accepted.

Bottom surveys are normally to be carried out with the ship in dry dock or on a slipway. If sea conditions and ship arrangements are such that an in-water survey can be satisfactorily carried out, see Ch.2 Sec.2 D300, bottom surveys may be

permitted while the ship is afloat, subject to the following conditions:

- Every alternate bottom surveys may in general be permitted while the ship is afloat.
- For general dry cargo ships as defined in Ch.2 Sec.2 I101 and ships with class notation **ESP** the bottom survey in conjunction with the renewal survey must be carried out with the ship in dry dock.
- For ships more than 15 years of age bottom surveys afloat will only be permitted after special consideration.
- For ships more than 15 years of age, with class notation **ESP**, bottom surveys afloat will not be permitted.
- For passenger ships two successive bottom surveys may be permitted while the ship is afloat, however, at least two bottom surveys must be carried out with the ship in dry dock in each five-year period of the classification certificate.

605 Surveys, survey intervals and time windows related to main class, mandatory class notations, additional class notations and survey arrangements are given in Table B2, Table B3, Table B4 and Table B5, respectively. Concurrent surveys are identified in the tables.

Guidance note:

"Concurrently completed" means that the survey must be completed prior to or at the same date as the "concurrent survey" and within the time window for that survey.

"Concurrently carried out" means that the survey must be completed within the time window for the "concurrent survey".

---e-n-d---of---G-u-i-d-a-n-c-e---n-o-t-e---

606 Ships with additional class notations for which there are no specific survey requirements shall have the equipment and/or constructions related to these additional class notations examined to the surveyor's satisfaction at every renewal survey for main class.

Table B2 Periodical surveys, main class 1A1. For survey extent, see Ch.2				
Survey type	Interval (years)	Time window (months)		Remarks
		W_B	W_A	
Main class survey - renewal	5	3	0	May be commenced up to 15 months prior to completion. A bottom survey shall be part of the survey.
Main class survey - intermediate	5	9	9	To be completed concurrently with the second or third annual survey main class.
Main class survey - annual	1	3	3	To be completed concurrently with the renewal survey main class, when due. In such case the time window W_A is 0.
Bottom	Maximum 3	0	0	See B604.
Tailshaft with continuous corrosion resistant metallic liner or shaft of corrosion resistant material or shaft with specially approved protection arrangement	5	3	3	
Tailshaft with oil sealing glands approved for minimum 5 years survey interval	5	3	3	May be extended up to 10 years provided a survey is carried out after 5 years as given in Ch. 2 Sec.2 E102. DNV may not require any specific time interval between complete tailshaft surveys, provided a tailshaft condition monitoring survey arrangement (TMON) has been granted (see Ch.2). However, dismantling of keyed propellers will be required every 5 years and keyless propellers every 15 years (see Ch.2).
Tailshaft with: — non-corrosion resistant material without continuous liner subject to seawater — oil sealing glands approved for less than 5 years survey interval	2.5	6	6	
Thruster for propulsion, intermediate	5	9	9	
Thruster for propulsion, complete	5	3	3	
Main boilers, less than 8 years old	2.5	6	6	
Watertube main boilers, more than 8 years old (2 or more boilers for propulsion)	2.5	6	6	
Watertube main boilers, more than 8 years old (1 boiler for propulsion)	1	3	3	
Smoketube main boilers, more than 8 years old	1	3	3	
Auxiliary boilers	2.5	6	6	
Steam heated steam generators	2.5	6	6	
Thermal oil heaters	2.5	6	6	
Hull survey general dry cargo ships - renewal	5	3	0	To be completed concurrently with the renewal survey main class. May be commenced up to 15 months prior to completion. A bottom survey in dock is required.
Hull survey general dry cargo ships - intermediate	5	9	9	To be completed concurrently with the intermediate survey main class. May be commenced up to 15 months prior to completion. A bottom survey is required for ships exceeding 15 years of age.
Hull survey general dry cargo ships - annual	1	3	3	To be completed concurrently with the annual survey main class. W_A is 0 when completed concurrently with the renewal survey.

Table B3 Periodical surveys, mandatory class notations. For survey extent, see Ch.2					
Class notation	Survey type	Interval (years)	Time window (months)		Remarks
			W_B	W_A	
Bulk Carrier ESP Ore Carrier ESP	Dry bulk cargo ships, annual	1	3	3	To be completed concurrently with the annual survey main class. W_A is 0 when completed concurrently with the renewal survey.
	Dry bulk cargo ships, intermediate	5	9	9	To be completed concurrently with the intermediate survey main class. A bottom survey in dock is required for ships exceeding 15 years of age.
	Dry bulk cargo ships, renewal	5	3	0	To be completed concurrently with the renewal survey main class. May be commenced up to 15 months prior to completion. A bottom survey in dock is required.
Tanker for Oil ESP Tanker for Oil Products ESP	Oil carriers, annual	1	3	3	To be completed concurrently with the annual survey main class. W_A is 0 when completed concurrently with the renewal survey.
	Oil carriers, intermediate	5	9	9	To be completed concurrently with the intermediate survey main class. A bottom survey in dock is required for ships exceeding 15 years of age.
	Oil carriers, renewal	5	3	0	To be completed concurrently with the renewal survey main class. May be commenced up to 15 months prior to completion. A bottom survey in dock is required.
Tanker for Chemicals ESP Tanker for C ESP	Tanker for chemicals, annual	1	3	3	To be completed concurrently with the annual survey main class. W_A is 0 when completed concurrently with the renewal survey.
	Tanker for chemicals, intermediate	5	9	9	To be completed concurrently with the intermediate survey main class. A bottom survey in dock is required for ships exceeding 15 years of age.
	Tanker for chemicals, renewal	5	3	0	To be completed concurrently with the renewal survey main class. May be commenced up to 15 months prior to completion. A bottom survey in dock is required.
Tanker for Liquefied Gas	Tanker for liquefied gas, annual	1	3	3	To be completed concurrently with the annual survey main class. W_A is 0 when completed concurrently with the renewal survey.
	Tanker for liquefied gas, intermediate	5	9	9	To be completed concurrently with the intermediate survey main class.
	Tanker for liquefied gas, renewal	5	3	0	To be completed concurrently with the renewal survey main class. May be commenced up to 15 months prior to completion.
Tanker for Compressed Natural Gas	Tanker for compressed natural gas, annual	1	3	3	To be completed concurrently with the annual survey main class. W_A is 0 when completed concurrently with the renewal survey.
	Tanker for compressed natural gas, intermediate	5	9	9	To be completed concurrently with the intermediate survey main class.
	Tanker for compressed natural gas, renewal	5	3	0	To be completed concurrently with the renewal survey main class. May be commenced up to 15 months prior to completion.
Passenger Ship, Car Ferry A (or B), Train Ferry A (or B) or Car and Train Ferry A (or B)	Annual	1	3	0	To be completed concurrently with the annual survey main class.
	Bottom survey	1	3	0	See B604 for additional requirements.

Table B4 Periodical surveys, additional class notations. For survey extent, see Ch.2

Class notation	Survey type	Interval (years)	Time window (months)		Remarks
			W_B	W_A	
Oil Production Vessel Oil Production and/ or Storage Vessel	Oil production vessel, annual	1	3	3	To be carried out concurrently with the annual survey main class. W_A is 0 when completed concurrently with the renewal survey main class.
	Oil production vessel, complete periodical	5	3	0	To be completed concurrently with the renewal survey main class. May be commenced up to 15 months prior to completion.
DSV	Diving system, annual	1	3	3	
	Diving system, intermediate	5	9	9	To be completed concurrently with the second or third annual survey for diving system.
	Diving system, complete periodical	5	3	3	To be completed concurrently with the annual survey for diving system.
Reefer, RM, RM Container, KMC CA	Cargo refrigerating plant, annual	1	3	3	To be carried out concurrently with the annual survey main class. W_A is 0 when completed concurrently with the renewal survey main class.
	Cargo refrigerating plant, complete periodical	5	3	0	To be completed concurrently with the renewal survey main class. May be commenced up to 15 months prior to completion.
TMON	Tailshaft monitoring, annual	1	3	3	
E0, ECO	Periodically unattended machinery space, annual	1	3	3	
	Periodically unattended machinery space, complete periodical	5	3	3	To be completed concurrently with the annual survey for E0 .
NAUT-C	Nautical safety, bridge design	5	3	3	
NAUT-OC-(Q) NAUT-AW-(Q) NAUT-A NAUT-B	Nautical safety, bridge design, instrumentation, manoeuvring, operational procedures	2.5	6	6	
ICS	Integrated computer systems	2.5	6	6	
DYNPOS-AUTS, DYNPOS-AUT, DYNPOS-AUTR DYNPOS-AUTRO	Dynamic positioning system	2.5	6	6	
F-AMC	Additional fire protection	2.5	6	6	
Fire Fighter	Fire fighters	2.5	6	6	
INERT	Inert gas installation	2.5	6	6	
PST	Protected slop tank	2.5	6	6	To be completed concurrently with the survey for Inert gas installation.
OILREC	Reception system for recovered oil	2.5	6	6	
CRANE, Crane Vessel	Shipboard crane, annual	1	3	3	To be carried out concurrently with the annual survey main class. W_A is 0 when completed concurrently with the renewal survey main class.
	Shipboard crane, complete periodical	5	3	0	To be completed concurrently with the renewal survey main class.
HELDK	Helicopter deck	5	3	0	To be completed concurrently with the renewal survey main class.
Car Carrier	Car carriers	1	3	3	
PET	Arrangement for carriage of motor vehicles with fuel in their tanks	1	3	3	
MCDK	Movable car decks	1	3	3	
Container Carrier	Container carriers	1	3	3	
Well Stimulation Vessel	Well stimulation vessels, annual	1	3	3	
	Well stimulation vessels, complete periodical	5	3	3	To be completed concurrently with the annual survey for well stimulation vessels.

Table B4 Periodical surveys, additional class notations. For survey extent, see Ch.2 (Continued)					
Class notation	Survey type	Interval (years)	Time window (months)		Remarks
			W_B	W_A	
Cable Laying Vessels	Cable laying vessel, annual	1	3	3	To be carried out concurrently with the annual survey main class W_A is 0 when completed concurrently with the renewal survey main class.
	Cable laying vessel, complete periodical	5	3	0	To be completed concurrently with the renewal survey main class
LFL or LFL*	Arrangements for carriage of low flashpoint liquids, annual	1	3	3	To be carried out concurrently with the annual survey main class. W_A is 0 when completed concurrently with the renewal survey main class.
	Arrangements for carriage of low flashpoint liquids, complete periodical	5	3	0	To be completed concurrently with the renewal survey main class.
Pusher, Pusher/ Barge	Pusher and pusher/barge combinations	5	3	0	To be completed concurrently with the renewal survey main class.
DEICE, DEICE/C	De-icing or anti-icing systems	1	3	3	
CCO	Centralised cargo control	5	3	3	
BOW LOADING	Bow loading arrangement	1	3	3	To be completed concurrently with the annual survey for Tanker for Oil. W_A is 0 when completed concurrently with the renewal survey main class.
POSMOOR (-V or -TA or -ATA)	Position mooring equipment, annual	1	3	3	For survey extent, see Offshore Standard DNV-OS-E301. To be carried out concurrently with the annual survey main class. W_A is 0 when completed concurrently with the renewal survey main class.
	Position mooring equipment, intermediate	5	9	9	For survey extent, see Offshore Standard DNV-OS-E301. To be completed concurrently with the second or third annual survey, POSMOOR.
	Position mooring equipment, complete periodical	5	3	0	For survey extent, see Offshore Standard DNV-OS-E301. To be completed concurrently with the renewal survey main class.
DG-P DG-B	Dangerous goods	5	3	3	
VCS-1 *) VCS-1B VCS-2 *) VCS-2B VCS-3 *)	Vapour control systems	5	3	0	To be completed concurrently with the renewal survey main class. *) No specific survey items. Complete periodical survey considered covered by renewal survey main class.
OPP-F *)	Additional oil pollution prevention measures for fuel oil systems	5	3	0	*) No specific survey items. Complete periodical survey considered covered by renewal survey main class.
HMON-1 HMON-2	Hull monitoring system	1	3	3	
CLEAN CLEAN DESIGN	Environment class, annual	1	3	3	To be carried out concurrently with the annual survey main class. W_A is 0 when completed concurrently with the renewal survey main class.
FUEL	Fuel, annual	1	3	3	To be carried out concurrently with the annual survey main class. W_A is 0 when completed concurrently with the renewal survey main class.
	Fuel, complete periodical	5	3	0	To be completed concurrently with the renewal survey main class.

Class notation	Survey type	Interval (years)	Time window (months)		Remarks
			W_B	W_A	
GAS FUELLED	Gas fuelled, annual	1	3	3	To be carried out concurrently with the annual survey main class. W_A is 0 when completed concurrently with the renewal survey main class.
	Gas fuelled, intermediate	5	9	9	To be completed concurrently with the second or third annual survey for gas fuelled.
	Gas fuelled, complete periodical	5	3	0	To be completed concurrently with the renewal survey main class.
SBM	Safety and environmental protection (SEP) management system, annual audit	1	3	3	The company may apply for intermediate audit after the first annual audit. When granted, the intermediate audit will replace the annual audit. See Ch.5 Sec.1 D402.
	Safety and environmental protection (SEP) management system, intermediate audit	5	6	6	Only applicable when the company has been granted intermediate audit status.
	Safety and environmental protection (SEP) management system, renewal audit	5	6	0	

Survey arrangement	Interval (years)	Time window (months) (see Fig.1)		Remarks
		W_B	W_A	
Integrated Survey Programme (ISP)	1	3	3	See Sec.5 for survey extent. To be carried out concurrently with the main class annual survey. W_A is 0 when completed concurrently with the renewal survey main class.
Hull continuous	5	6	0	All items are normally to be surveyed during the 5 year class period. See Sec.5.
Machinery continuous	5	6	0	All items are normally to be surveyed during the 5 year class period. See Sec.5 and Ch.8.
Machinery - PMS, annual	1	3	3	To be carried out concurrently with the E0, ECO survey - if applicable. See Ch.8 for survey extent
Machinery - CM, annual	1	3	3	See Ch.8 for survey extent
Machinery - CM, renewal	5	6	0	See Ch.8 for survey extent

B 700 Postponement of periodical surveys

701 Except for annual and intermediate surveys for main and mandatory class notations, DNV may accept to postpone periodical surveys upon consideration in each separate case. If postponement is granted, a condition of class (CC) will be issued giving the time limit for the postponement period.

702 Normally, postponement of a periodical survey will not affect the survey's next due date.

703 In exceptional cases and upon the owner's written request a postponement of the renewal survey for main and mandatory class notation with subsequent extension of the validity of the classification certificate by maximum 3 months may be granted.

Such a request shall be received by DNV well in advance of the expiry date of the classification certificate.

A sighting survey with the extent equal to an annual survey shall normally be carried out in order to grant such postponement.

Guidance note:

A sighting survey is a survey to confirm that the relevant construction or the equipment is in a satisfactory condition and, as far as can be judged, will remain so until the postponed survey has been carried out.

---e-n-d---of---G-u-i-d-a-n-c-e---n-o-t-e---

B 800 Survey of ships out of commission

801 Ships which have been out of commission, i.e. laid up,

for a period normally of at least 12 months, shall be surveyed and tested before re-entering service. The extent of the surveys and tests will be considered in each case depending upon:

- the time the ship has been out of commission
- the maintenance and preservative measures taken during lay-up
- the extent of surveys carried out during this time.

As a minimum, a sea trial for function testing of the machinery installation shall be carried out.

802 During lay-up, ships shall be subjected to annual survey. The extent of the annual survey will be reduced compared to main class annual survey, but shall cover watertight integrity, bilge system, fire hazard and equipment in use.

803 If the lay-up period is more than 12 months, other periodical surveys may be postponed, depending on the maintenance and preservative measures taken during lay-up.

C. Classification Certificate

C 100 Certificate endorsement

101 The classification certificate will be endorsed upon satisfactory completion of annual and intermediate surveys for main and mandatory class notations. The validity of the classification certificate may be extended upon satisfactory completion of renewal survey for main and mandatory class notations. Endorsement of the classification certificate or issue of a new

certificate means that the ship is accepted for retention of class. The certificate will not be endorsed or extended in case of:

- non-satisfactory completion of the survey(s)
- any overdue periodical class survey including continuous survey if applicable
- overdue conditions of class.

Guidance note:

In case an overdue survey related to a notation, that is not mandatory, the classification certificate may be endorsed provided this class notation is suspended.

---e-n-d---of---G-u-i-d-a-n-c-e---n-o-t-e---

102 In case the main class annual survey is performed prior to the defined time window, the anniversary date on the classification certificate will be advanced. Subsequent surveys shall be carried out at prescribed intervals using the new anniversary date.

Guidance note:

Expiry date of the classification certificate may remain unchanged, but additional surveys may be required so that the prescribed survey intervals are not exceeded.

---e-n-d---of---G-u-i-d-a-n-c-e---n-o-t-e---

C 200 Validity of the Classification Certificate

201 When the classification certificate has been extended or an interim certificate has been issued, a new classification certificate will be issued after the administration has examined the surveyor's report and is satisfied that the applicable requirements have been met.

202 The validity of the classification certificate given in 201 will be 5 years if the annual and intermediate surveys as given in B are carried out at intervals and within the time windows required.

203 For certain ships the certificate validity and survey intervals may be reduced by the administration, e.g. for ships with new or novel design or for systems or items exposed to abnormal rate of wear or failure.

C 300 Issue of Classification Certificate and expiry date

301 For renewal surveys completed within 3 months before the expiry date of the existing certificate, the new certificate will be valid to a date not exceeding 5 years from the expiry date of the existing certificate.

302 For renewal surveys completed after the expiry date of the existing certificate, the new certificate will be valid to a date not exceeding 5 years from the expiry date of the existing certificate.

303 In cases where postponement of renewal surveys have been granted as given in B700, the new certificate will be valid to a date not exceeding 5 years from the expiry date of the existing certificate before the extension was granted.

304 For renewal surveys completed more than 3 months before the expiry date of the existing certificate, the new certificate will be valid to a date not exceeding 5 years from the completion date of the renewal survey.

305 In cases where the renewal surveys are carried out concurrently with major conversions and or alterations requiring a long conversion time, the validity of the new certificate will normally be 5 years from the date of the completion of conversion and/or alteration.

SECTION 3 GENERAL REQUIREMENTS FOR HULL AND MACHINERY SURVEYS

A. General

A 100 Surveyor's safety

101 The owner shall provide the necessary facilities for safe execution of surveys, see Pt.1 Ch.1 Sec.3 B102.

102 Tanks and spaces shall be safe for access, i.e. gas freed, ventilated, cleaned and sufficient illumination shall be provided. This also applies to access requirements and the cleaning of areas in way of the surveyor's route.

103 For overall and close-up examination, means shall be provided to enable the surveyor to examine the structure in a safe and practical way.

B. Requirements for Hull Surveys

B 100 Conditions for survey and access to structures

101 Tanks and spaces shall be sufficiently illuminated, clean and free from water, scale, dirt, oil residues, etc. to reveal significant corrosion, deformation, fractures, damages or other structural deterioration. In particular this applies to areas that are subject to thickness measurement. In tanks where soft coatings have been applied, representative areas and those areas where it is obvious that further close-up examination is required shall be cleaned free of soft coating.

Guidance note:

For more detailed information with regard to a tank where soft coatings have been applied, see IACS Recommendation No. 44.

---e-n-d---of---G-u-i-d-a-n-c-e---n-o-t-e---

102 For close-up examination, one or more of the following means for access shall be provided:

- permanent staging and passages through structures
- temporary staging and passages through structures
- lifts and moveable platforms
- boats or rafts
- other equivalent means.

B 200 Thickness measurements, hull structures

201 Thickness measurements shall be carried out by a qualified company approved by DNV.

Thickness measurements shall normally be carried out by means of ultrasonic test equipment. The accuracy of the equipment shall be proven to the surveyor as required.

202 The thickness measurements is to be carried out with a surveyor in attendance. A survey meeting is to be held prior to commencing the survey. The thickness measurement operator is to be part of the meeting together with representatives from the owner and DNV.

203 A thickness measurement report shall be prepared. The report shall give the location of the measurements, the thickness measured and the corresponding original thickness. Furthermore, the report shall give the date when the measurements were carried out, type of measuring equipment, names of personnel and their qualifications. The report shall be signed by the responsible operator. The surveyor shall verify and countersign the report.

Guidance note:

The single measurements recorded should represent the average of multiple measurements.

---e-n-d---of---G-u-i-d-a-n-c-e---n-o-t-e---

Guidance note:

For more information on reporting of thickness measurements, see DNV Guidelines, DNV Recommended Reporting Principles for Ultrasonic Thickness Measurements of Hull Structures.

---e-n-d---of---G-u-i-d-a-n-c-e---n-o-t-e---

B 300 Repair of structural damage or deterioration

301 A prompt and thorough repair is a permanent repair completed at the time of survey to the satisfaction of the surveyor, therein removing the need for the imposition of any associated condition of class.

302 Any damage in association with wastage over the allowable limits (including buckling, grooving, detachment or fracture), or extensive areas of wastage over the allowable limits, which affects or, in the opinion of the surveyor, will affect the ship's structural, watertight or weathertight integrity, shall be promptly and thoroughly repaired. Areas to be considered include:

- side shell frames, their end attachments or adjacent shell plating
- deck structure and deck plating
- bottom structure and bottom plating
- watertight or oiltight bulkheads
- hatch covers or hatch coamings.

303 For locations where adequate repair facilities are not available, consideration may be given to allow the ship to proceed directly to a repair facility. This may require discharging the cargo and or temporary repairs for the intended voyage.

304 Additionally, when a survey results in the identification of significant corrosion or structural defects, either of which, in the opinion of the surveyor, will impair the ship's fitness for continued service, remedial measures shall be implemented before the ship continues in service.

C. Requirements for Machinery Surveys

C 100 Maintenance system

101 Every ship shall have implemented a maintenance system including machinery system and equipment subject to class (see Ch.8 Sec.1 Table A1). The maintenance system shall ensure that:

- inspections and maintenance are carried out at defined intervals
- records of these activities are maintained.

Guidance note:

The maintenance system may be manual or computerised.

---e-n-d---of---G-u-i-d-a-n-c-e---n-o-t-e---

C 200 Shaft alignment

201 For propulsion systems where shaft alignment calculations have been required, the alignment shall be confirmed by suitable measurements when the system has been dismantled and or when external forces (e.g. grounding, welding work)

may have influenced the alignment.

The measurements shall be carried out with the ship afloat and be presented to the surveyor on request.

Guidance note:

Relevant methods for making measurements are:

- bearing loads checked by jacking
- bending stress measurements (strain gauge readings)
- other approved methods.

---e-n-d---of---G-u-i-d-a-n-c-e---n-o-t-e---

202 The measured values shall be within the initially approved tolerances.

C 300 Replacement of machinery components

301 When machinery components are renewed, such components should in general be delivered in accordance with requirements as per valid rules at the time of newbuilding, see Pt.1 Ch.1 Sec.3 B1000.

Guidance note:

For guidance regarding spare parts for ships in operation see Pt.4 Ch.2 Sec.2 A100.

---e-n-d---of---G-u-i-d-a-n-c-e---n-o-t-e---

Guidance note:

- 1) If the relevant rule requires an NV certificate for the actual part, then the design and the survey, as relevant, should be in accordance with the applicable rule requirement. Applicable for diesel engines: The actual part should be produced by a manufacturer authorised by the engine designer or the designer's licensee.
- 2) If the relevant rule requires a Work certificate for the actual part:
 - when design approval is required, the certificate should confirm compliance with the relevant parts (e.g. NDT, material, dimensions, etc.) of the approved drawings and specifications
 - when no design approval is required (i.e. drawings and specifications submitted for information only), the required certificate should confirm compliance with the applicable rule requirements (e.g. pressure testing, NDT, etc.).

Applicable for diesel engines: If the part is produced by a manufacturer not authorised by the engine designer or the designer's licensee, DNV may carry out inspections according to Pt.4 Ch.3 Sec.1 Table C1 and issue a report confirming this. However, this inspection report will not cover design approval and testing as a part of the engine. It is the operator's responsibility to evaluate and take the necessary precautions to see that the parts are fit for their intended use.

---e-n-d---of---G-u-i-d-a-n-c-e---n-o-t-e---

C 400 Machinery verification

401 At the time of drydocking, a dock trial is to be carried out to confirm satisfactory operation of main and auxiliary ma-

chinery. If significant repairs are carried out to main or auxiliary machinery, or steering gear, consideration should be given to perform a sea trial to the attending surveyor's satisfaction.

Guidance note:

1. Significant Repair:

The following are not defined as significant repairs:

Routine maintenance of the engine; such as

- unit overhaul (piston, cylinder head, liner)
- turbocharger overhaul
- bearing inspections
- renewal of cracked liners
- renewal of cylinder heads
- use of new spares parts
- use of reconditioned parts
- open up and overhaul of units and bearings
- welding repair in the thrust bearing ribs.

A *significant repair* is one where the engine is completely dismantled and re-assembled, in cases such as renewal of crankshaft, bedplate, engine entablature renewal. Significant repairs will, furthermore, be cases of repairs after serious damage to the engine after fire or flooding of the engine room resulting from e.g. collision or grounding of the ship.

2. Scope of Testing:

Main Engine:

- a) Sea trial: Upon complete reassembly after bedplate or crankshaft renewal, testing as for a new engine is required. The service engineer of the manufacturer's prepared test program should be used by the attending surveyor.
- b) Dock trial: Generally, the testing should be limited to the following tests, which typically can be carried out alongside:
 - start / stop / reversing
 - local / remote operation
 - random safety alarms and cut-outs, including emergency stop.

Auxiliary Engines:

Generally, the testing can be done alongside (shipyard or at other wharf), and does not necessarily require a sea trial. Testing as follows is recommended:

- start / stop
- local / remote operation
- random safety alarms and cut-outs, including over speed and emergency stop
- parallel running and load test.

Steering gears:

Trial performed alongside is normally sufficient.

In certain case (e.g. modifications, insurance and vetting cases) testing at ship's full speed may be required, for which a sea trial will be necessary. Largely handled case by case, calling for surveyor's experienced assessment. Owners typically will not raise objection related to this issue, and actually are likely to request DNV to attend the sea trial and issue statement thereafter.

---e-n-d---of---G-u-i-d-a-n-c-e---n-o-t-e---

SECTION 4 REQUIREMENTS FOR ENHANCED SURVEY PROGRAM (ESP)

A. General

A 100 Application

101 Requirements given in 200 and 300 apply to the hull renewal survey for ships with notation **ESP**.

A 200 Survey programme

201 A specific survey programme shall be worked out in advance of the hull renewal survey or complete periodical survey by the owner in co-operation with DNV. The survey programme shall be in the written format.

202 The following documentation shall be collected and consulted with a view to selecting tanks, holds, areas and structural elements to be examined:

- survey status and basic ship information
- documentation on board as described in 300
- main structural plans, including information regarding use of high strength steel, stainless steel and clad steel
- relevant previous survey or inspection reports from DNV and the owner
- information regarding the use of the ship's tanks and holds with particular emphasis on typical cargoes
- information regarding corrosion protection system
- information regarding maintenance during operation.

203 The submitted survey programme shall account for and comply with, as a minimum, the requirements for close-up examination, thickness measurements and tank testing as given in Pt.7 Ch.2 Sec.3 as relevant for the ship's class notation.

204 The submitted survey programme is, in addition to the requirements given in 203, to include relevant information including at least:

- basic ship information and particulars
- main structural plans including information on the use of high strength steel, stainless steel and clad steel
- plan of tanks and holds
- list of tanks and holds with information on use, corrosion protection and condition of corrosion protection
- condition for survey such as cleaning of tanks and holds, gas freeing, ventilation, lighting, etc.
- provisions and methods for access to structures
- equipment for survey
- nomination of tanks, holds and areas for close-up examination
- nomination of sections for thickness measurements
- nomination of tanks to be tested

— damage experience related to the ship in question and, as applicable, for similar ships.

205 The extent of survey as described in the survey programme may be extended as found necessary by DNV based on the results of the survey.

Guidance note:

For more detailed information in conjunction with the preparation of the survey programme, see DNV Guidelines, Renewal Survey, Survey Planning.

---e-n-d---of---G-u-i-d-a-n-c-e---n-o-t-e---

206 A survey planning meeting is to be held prior to commencing the renewal survey. The thickness measurement operator is to be part of the meeting together with representatives from the owner and DNV.

A 300 Documentation on board

301 The owner shall supply and maintain on board documentation as specified in 303 and 304, which shall be readily available for the surveyor.

302 The documentation shall be kept on board for the lifetime of the ship.

303 A survey report file consisting of:

- reports of structural surveys
- executive hull summary
- thickness measurements reports
- survey programme,

shall be available on board. The survey report file shall be available also in the owner's and DNV's offices.

304 The following additional documentation shall be available on board:

- main structural plans of cargo and ballast holds or tanks
- previous repair history
- cargo and ballast history
- extent of use of inert gas plant and tank cleaning procedures
- records of inspections and actions by ship's personnel with reference to:
 - structural deterioration in general
 - leakage in bulkheads and piping
 - condition of coating or corrosion protection, if any
 - any other information that will help to identify critical structural areas and/or suspect areas requiring inspection.

SECTION 5

ALTERNATIVE SURVEY ARRANGEMENTS AND SURVEYS PERFORMED BY APPROVED COMPANIES

A. Alternative Survey Arrangements

A 100 General overview of survey arrangements

101 Alternative survey arrangements may be accepted as an option to applicable periodical surveys for main class.

102 The following survey arrangements may be granted upon written request from the owner:

- *Hull continuous*, a survey arrangement that includes all the ship's hull compartments and structure.
- *Integrated survey programme, ISP*, a survey arrangement for hull structures and equipment of container ships with the class notation **Container Carrier**, see 400.
- *Machinery continuous*, a survey arrangement based on surveys of the machinery items as detailed in Ch.8.
- *Machinery PMS*, a survey arrangement based on a planned maintenance system. The requirements are detailed in Ch.8.
- *Machinery CM*, a survey arrangement that can include selected parts of the machinery, and is not covering the complete machinery installation onboard. The requirements are detailed in Ch.8.

A 200 Continuous surveys, general

201 Continuous surveys comprise continuous hull and or machinery surveys.

202 The items are normally to be surveyed at intervals not exceeding 5 years. Surveys carried out 6 months or less before their due date will be given a correspondingly longer interval during the next cycle.

203 Further requirements for continuous machinery surveys are detailed in Ch.8.

A 300 Continuous hull survey

301 Continuous hull survey may be accepted for ships where an additional class notation as listed below, has been assigned:

Passenger Ship

Car Ferry

Train Ferry

Tanker for Liquefied Gas

Tanker for Compressed Natural Gas

Container Carrier

Ro/Ro

A 400 Integrated survey programme (ISP), hull structures and equipment

401 The rules in 400 represent an alternative survey scheme and allows the owner's shipboard and shore personnel, as given in 402, to partly conduct inspections and tests as described in 403. The inspections and tests shall be verified by DNV at regular intervals as given in 412.

402 ISP is applicable for ships exclusively intended for the carriage of containers, normally with the class notation **Container Carrier**. The rules apply to ships with operational patterns which allow a planned and controlled implementation of the program and application of the ISP will be restricted to ships above a certain size, normally with a cargo carrying capacity of not less than 1 000 TEU.

It is a prerequisite that the ship has a valid safety management certificate (SMC) in accordance with the ISM Code.

403 ISP covers inspections of hull structures and equipment to the extent subject to class surveys as given in Ch.2 Sec.2 and supporting fittings, structures and equipment for stowing and securing of containers as given in Ch.2 Sec.3 B.

Guidance note:

Inspection in this context means visual examination and/or pressure test.

---e-n-d---of---G-u-i-d-a-n-c-e---n-o-t-e---

404 The requirements given in 405 to 416 replace requirements given for periodical and continuous hull surveys carried out by DNV with an integrated survey program (ISP) which describes specific obligations for the owner and DNV based on the ship's arrangement, installed equipment and systems as well as implemented planned inspection and maintenance system (PIMS).

405 Intervals for planned inspections and maintenance shall be decided based on the owner's documented experience and/or designers, builders and manufacturers recommendations. Intervals for examination of hull structures and equipment covered by ISP, according to 403 are, however, supposed to be shorter than intervals given for periodical surveys in Sec.2 C, applicable for intermediate and renewal surveys, respectively.

406 Upon request from the owner, an enrolment letter for ISP will be issued when documents listed in a) to d) have been submitted by the owner and reviewed by DNV and the initial survey as given in 411 has been successfully carried out:

- a) Information related to conditions given in 402.
- b) PIMS.
- c) An organisation chart with defined responsibilities, authorities and interrelations of all personnel who manage, perform and verify work in accordance with ISP.
- d) Qualification and competency of personnel to perform their assigned functions under the ISP.

Guidance note:

It is assumed that the master's responsibility and authority as defined in the ISM Code paragraph 5 are maintained with the ISP.

The owner should have a plan on how to provide personnel involved in the ISP with adequate understanding of relevant rules and reporting principles, basic knowledge of structural arrangement and hull integrity with respect to design, strength and maintenance.

This may include establishment and maintenance of procedures for identifying any training, which may be required in support of the ISP and to ensure that such training is provided.

In order not to impose a redundant burden, ISM Code documents sufficiently detailed may be suitable also for use in the ISP and owner may submit copies of documents of the safety management components that meet requirements for the ISP.

---e-n-d---of---G-u-i-d-a-n-c-e---n-o-t-e---

407 The following examinations and tests shall be carried out under the supervision of a surveyor:

- a) Thickness measurement of hull structures as given in Ch.2 Sec.2 B and C. Requirements given in Sec.3 B200 apply. Holds or tanks or spaces required to be entered for thickness measurement shall be internally examined.
- b) Examination of underwater parts in connection with periodical bottom survey. In connection with dry-docking, holds, tanks and spaces shall be internally examined to an

extent decided by DNV in order to verify structural condition and level of maintenance as reported as part of the PIMS and shall comprise representative holds, tanks and spaces as applicable.

- c) Annual examination of ballast tanks required as a consequence of non-effective corrosion protection system.
- d) Annual examination and thickness measurement of suspect areas as given in Ch.2 Sec.2 A203.

408 The PIMS shall, as a minimum, include a description of the following:

- identification of all items included
- inspection and maintenance intervals
- inspection and maintenance methods and procedures to be followed
- inspection and maintenance reporting procedures
- procedure for corrective actions following reported deficiencies.

Guidance note:

The inspection of hull structures should include plating, frames, beams, stiffeners and girders including end connections and welds of all internal members and boundaries for holds, tanks and spaces including hatch covers and coamings as applicable. Evaluation of the condition of corrosion protection system in ballast tanks and other holds and spaces as applicable should be included. Piping systems located outside machinery spaces including valves and fittings should be included. Importance of provisions for inspection with particular attention to cleanliness and access to structures in order to discover significant corrosion, deformation, fractures or other structural deterioration should be incorporated.

Guidelines for assessment of acceptance level of deterioration on hull structures and equipment as applicable and evaluation of protective coating condition will be given as part of the ISP.

Reporting forms should, as a principle, give information on:

- extent of inspection and maintenance with identification of spaces and specification of structural elements, equipment, pipes, fittings etc. as applicable within each space being inspected
- results of inspection with condition of coating and anodes (if applicable), structural condition with identification of findings as corrosion and defects like cracks, buckling and indents and actions to possible findings including maintenance work.

Sketches and photos should generally supplement reports.

---e-n-d---of---G-u-i-d-a-n-c-e---n-o-t-e---

409 The PIMS shall include records applicable to inspections, maintenance, damages, defects and carried out corrective actions. These shall be kept as objective evidence of the condition of hull structures and equipment and the effective functioning of the PIMS. The records shall be readily accessible to the attending surveyor.

Guidance note:

In order to provide flexibility in the method of documentation, any appropriate record keeping system may be incorporated in the PIMS including computer-based system. In order to assist the surveyor to conduct the requisite annual surveys as given in 412 without difficulty, suitable cross-referencing may be required.

---e-n-d---of---G-u-i-d-a-n-c-e---n-o-t-e---

410 The implementation of ISP requires that descriptive data related to the structural condition and level of maintenance for items included are established.

Guidance note:

Relevant data may be obtained based on results from periodical surveys and/or condition survey and further supported with information available from classification records.

---e-n-d---of---G-u-i-d-a-n-c-e---n-o-t-e---

411 After satisfactory review of documentation listed in 406 and after the PIMS has been in operation onboard for a specific time of normally not less than 6 months, an initial survey shall be carried out to confirm that the ISP is operating as intended.

Guidance note:

During the initial operational period, DNV will evaluate the ability of ship operating personnel to perform their assigned functions.

---e-n-d---of---G-u-i-d-a-n-c-e---n-o-t-e---

412 An annual survey is required in order to retain validity of the ISP. The survey shall include:

- ISP performance review with verification that the conditions for the enrolment of ISP are maintained
- examination of PIMS records with regard to inspections and maintenance carried out since last annual survey including description of corrective actions taken in response of reported deficiencies.

If deemed necessary by the surveyor, based on the review of inspection and maintenance records, or acceptance criteria given as part of the ISP are exceeded, examination and or test, under the supervision of a surveyor, is required. Based on a satisfactory result, the validity of the ISP will be extended until the next annual survey. Requirements in Ch.2 Sec.3 B200 apply.

413 If service experience shows wear and tear or defects that cannot be considered as normal, this shall be reported to DNV. In such cases the owner shall initiate, in co-operation with DNV, a special investigation to identify the cause(s). DNV may require the inspection and maintenance interval shortened until suitable corrective actions have been implemented.

414 If the hull structure and or equipment covered by the ISP sustain damage to such an extent that it may be presumed to lead to a condition of class (see Pt.1 Ch.1 Sec.3 B), DNV shall be informed without delay. The ship shall be surveyed in the first port of call or according to further instructions from DNV.

415 Should it be evident that the conditions for the ISP enrolment or the effective functioning of ISP as basis for retention of class are not complied with, the ISP enrolment will be cancelled and conditions for ordinary periodical or continuous survey schemes will be introduced.

416 If the owner and or operator of the ship is changed, the ISP enrolment will be automatically cancelled.

B. Surveys by Approved Companies or Service Suppliers

B 100 General

101 Parts of the periodical surveys may be carried out by companies approved by DNV. The following survey parts may be performed by such companies:

- thickness measurements
- examination of ro-ro ships bow, side and stern doors
- bottom survey afloat.

B 200 Thickness measurements

201 The requirements given in Sec.3 B200 apply.

B 300 Examination of ro-ro ships' bow, side and stern doors

301 Companies engaged by the owner in the inspections of ro-ro ships' bow (outer and inner), side and stern doors, the results of which may form the basis for the surveyor's decisions, shall be approved by DNV.

302 Inspections according to 301 may include locking arrangement and supports, cleats, hydraulic operating system, electric control and indicator or monitoring systems, sealing arrangement and tightness testing.

Guidance note:

Inspections encompass visual examination, NDT of vital elements (i.e. dye penetrant, magnetic particle inspection) and measurement of clearances.

---e-n-d---of---G-u-i-d-a-n-c-e---n-o-t-e---

303 An inspection report shall be prepared. The report shall give information on arrangement and systems covered by the inspection and the results of visual examination and tests as applicable. Furthermore, the report shall give the date when the inspection was carried out, type of test equipment, names of

personnel and their qualifications. The report shall be signed by the person in charge.

Guidance note:

For more information on reporting, see Standard for Certification No. 2.9, Type Approval Programme No. 409.

---e-n-d---of---G-u-i-d-a-n-c-e---n-o-t-e---

304 Upon satisfactory review of the inspection report, DNV may agree to limit the extent of annual surveys, see Ch.2 Sec.2 A300.

B 400 Bottom survey afloat

401 An approved diving company to be used. The survey is to be witnessed by a DNV surveyor. Detailed requirements are given in Ch.2.

SECTION 6 RETROACTIVE RULE REQUIREMENTS

A. Existing Bulk Carriers - Corrugated Transverse Watertight Bulkheads considering Cargo Hold Flooding

A 100 Application and definition

101 These requirements apply to all bulk carriers of 150 m in length and above, in the foremost hold, subject to mandatory class notation **Bulk Carrier ESP**, intending to carry solid bulk cargoes having a density of 1.78 t/m³ or above, with single deck, topside tanks and hopper tanks and fitted with vertically corrugated transverse bulkheads between cargo holds no. 1 and 2. Where:

- i) the foremost hold is bounded by the side shell only for ships which were contracted for construction prior to 1 July 1998, and have not been constructed in compliance with IACS Unified Requirement S18.
- ii) the foremost hold is double side skin construction of less than 760 mm breadth measured perpendicular to the side shell in ships, the keel of which was laid, or which was at a similar stage of construction, before 1 July 1999 and has not been constructed in compliance with IACS Unified Requirement S18. (Rev.2, Sept. 2000).

These requirements apply to vertically corrugated transverse watertight bulkheads between cargo hold no. 1 and 2.

The net thickness t_{net} is the thickness obtained by applying the strength criteria as given in 301 to 308.

The required thickness is obtained by adding the corrosion addition t_s , given in 500, to the net thickness t_{net} .

In this requirement, homogeneous loading condition means a loading condition in which the ratio between the highest and the lowest filling ratio, evaluated for each cargo hold, does not exceed 1.2 (corrected for different cargo densities).

The requirements shall, at the latest, be complied with as follows:

- i) for ships which were 20 years of age or more on 1 July 1998, by the due date of the first intermediate, or the due date of the first renewal survey to be held after 1 July 1998, whichever comes first;
- ii) for ships which were 15 years of age or more but less than 20 years of age on 1 July 1998, by the due date of the first renewal survey to be held after 1 July 1998, but not later than 1 July 2002;
- iii) for ships which were 10 years of age or more but less than 15 years of age on 1 July 1998, by the due date of the first intermediate or the first renewal survey to be held after the date on which the ship reaches 15 years of age but not later than the date on which the ship reaches 17 years of age;
- iv) for ships which were 5 years of age or more but less than 10 years of age on 1 July 1998, by the due date, after 1 July 2003, of the first intermediate or first renewal survey after the date on which the ship reaches 10 years of age, whichever occurs first;
- v) for ships which were less than 5 years of age on 1 July 1998, by the date on which the ship reaches 10 years of age.

Thickness measurements are to be taken according to Ch.2 Sec.3 F500 prior to the relevant compliance deadline.

A 200 Load model

201 General

The loads to be considered as acting on the bulkhead are those given by the combination of the cargo loads with those induced by the flooding of cargo hold no. 1. The most severe combinations of cargo induced loads and flooding loads are to be used for the check of the scantlings of the bulkhead, depending on the loading conditions included in the loading manual:

- homogeneous loading conditions
- non-homogeneous loading conditions.

Non-homogeneous part loading conditions associated with multipoint loading and unloading operations for homogeneous loading conditions need not be considered according to these requirements.

202 Bulkhead corrugation flooding head

The flooding head h_f (see Fig.1) is the distance in m, measured vertically with the ship in the upright position, from the calculation point to a level located at a distance d_f , in m, from the baseline equal to:

- a) in general:
D for the foremost transverse corrugated bulkhead.
- b) for ships less than 50 000 tonnes deadweight with B freeboard:
0.95 D for the foremost transverse corrugated bulkhead.
- c) for ships to be operated at an assigned load line draught T_r less than the permissible load line draught T, the flooding head defined in a) and b) above may be reduced by $T - T_r$.

203 Pressure in non-flooded bulk cargo loaded hold

At each point of the bulkhead, the pressure p_c , in kN/m², is given by:

$$p_c = \rho_c g h_1 K$$

- ρ_c = bulk cargo density, in t/m³
- g = 9.81 m/s², gravity acceleration
- h_1 = vertical distance, in m, from the calculation point to horizontal plane corresponding to the volume of the cargo (see Fig.1), located at a distance d_1 , in m, from the baseline
- K = $\sin^2 \alpha \tan^2 (45 - 0.5 \delta) + \cos^2 \alpha$
- α = angle between panel in question and the horizontal plane, in degrees
- δ = angle of repose of the cargo, in degrees, that may generally be taken as 35° for iron ore.

$$d_1 = \frac{M_c}{\rho_c l_c B} + \frac{V_{LS}}{l_c B} + (h_{HT} - h_{DB}) \frac{b_{HT}}{B} + h_{DB}$$

- M_c = mass of cargo, in tonnes, in cargo hold no. 1
- ρ_c = bulk cargo density, in t/m³
- l_c = length of cargo hold no. 1, in m
- V_{LS} = volume, in m³, of the bottom stool above the inner bottom
- h_{HT} = height of the hopper tanks amidship, in m, from the base line
- h_{DB} = height of the double bottom, in m
- b_{HT} = breadth of the hopper tanks amidship, in m
- B = ships breadth amidship.

The force F_c , in kN, acting on a corrugation is given by:

$$F_c = \rho_c g s_1 \frac{(d_1 - h_{DB} - h_{LS})^2}{2} K$$

- s_1 = spacing of corrugations, in m (see Fig.2)
- h_{LS} = mean height of the lower stool, in m, from the inner bottom
- h_{DB} = height of the double bottom, in m.

ρ_c, g, d_1, K = as given above

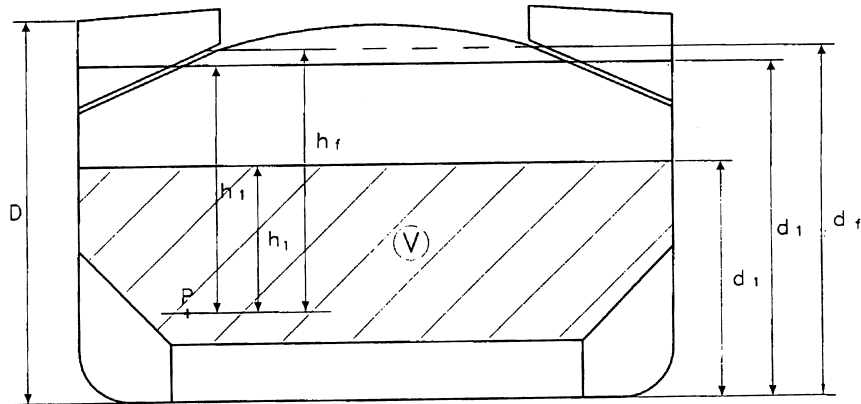

V = Volume of cargo

P = Calculation point

Fig. 1
Definition of D, h₁ and d₁

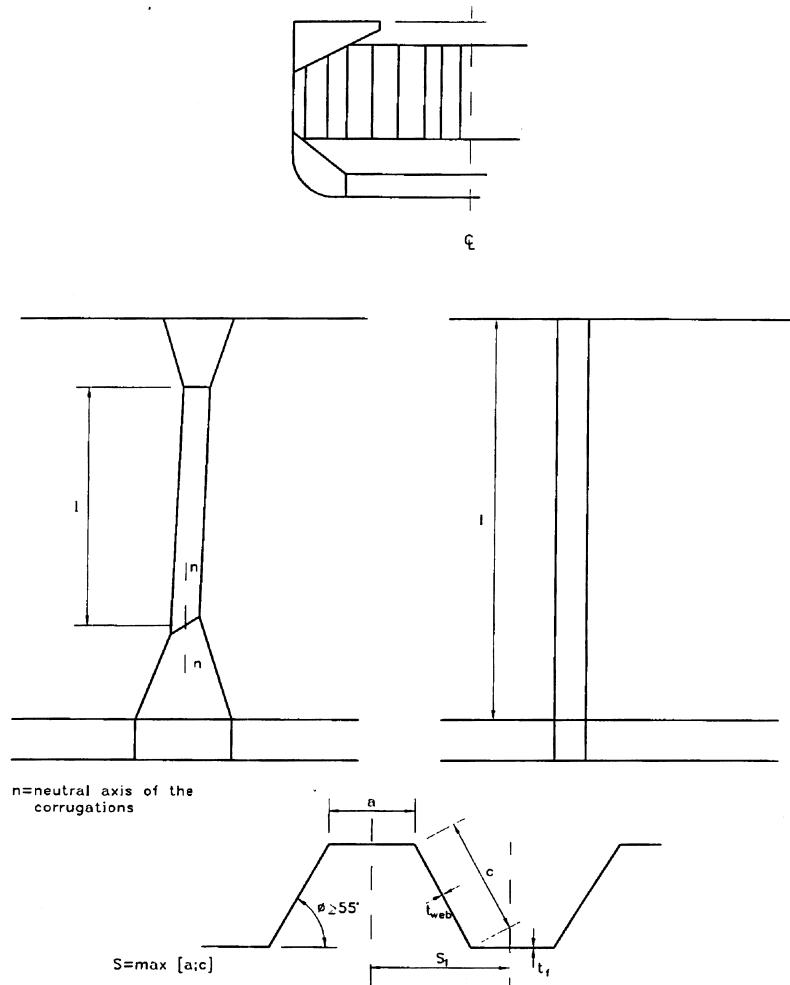

Fig. 2
Spacing of corrugations

204 Pressure in flooded bulk cargo holds

Two cases are to be considered, depending on the values of d_1 and d_f .

a) $d_f \geq d_1$

At each point of the bulkhead located at a distance between d_1 and d_f from the baseline, the pressure $p_{c,f}$, in kN/m^2 , is given by:

$$p_{c,f} = \rho g h_f$$

ρ = sea water density, in t/m^3

g = as given in 203

h_f = flooding head as defined in 202.

At each point of the bulkhead located at a distance lower than d_1 from the baseline, the pressure $p_{c,f}$, in kN/m^2 , is given by:

$$p_{c,f} = \rho g h_f + [\rho_c - \rho(1 - \text{perm})] g h_1 K$$

ρ, h_f = as given above

ρ_c, g, h_1, K = as given in 203

perm = permeability of cargo, to be taken as 0,3 for ore (corresponding bulk cargo density for iron ore may generally be taken as 3.0 t/m^3).

The force $F_{c,f}$, in kN, acting on a corrugation is given by:

$$F_{c,f} = s_1 \left[\rho g \frac{(d_f - d_1)^2}{2} + \frac{\rho g (d_f - d_1) + (p_{c,f})_{le} (d_1 - h_{DB} - h_{LS})}{2} \right]$$

ρ = as given above

s_1, g, d_1 = as given in 203

h_{DB}, h_{LS} = as given in 203

d_f = as given in 202

$(P_{c,f})_{le}$ = pressure, in kN/m^2 , at the lower end of the corrugation.

b) $d_f < d_1$

At each point of the bulkhead located at a distance between d_f and d_1 from the baseline, the pressure $p_{c,f}$, in kN/m^2 , is given by:

$$p_{c,f} = \rho_c g h_1 K$$

ρ_c, g, h_1, K = as given in 203.

At each point of the bulkhead located at a distance lower than d_f from the baseline, the pressure $p_{c,f}$, in kN/m^2 , is given by:

$$p_{c,f} = \rho g h_f + [\rho_c h_1 - \rho(1 - \text{perm}) h_f] g K$$

ρ, h_f, perm = as given in a) above

ρ_c, g, h_1, K = as given in 203.

The force $F_{c,f}$, in kN, acting on a corrugation is given by:

$$F_{c,f} = s_1 \left[\rho_c g \frac{(d_1 - d_f)^2}{2} K + \frac{\rho_c g (d_1 - d_f) K + (p_{c,f})_{le} (d_f - h_{DB} - h_{LS})}{2} \right]$$

s_1, ρ_c, g, d_1 = as given in 203

h_{DB}, h_{LS}, K = as given in 203

d_f = as given in 202

$(P_{c,f})_{le}$ = pressure, in kN/m^2 , at the lower end of the corrugation.

205 Empty cargo holds and pressure due to flooding water alone

At each point of the bulkhead, the hydrostatic pressure p_f induced by the flooding head h_f is to be considered.

The force F_f , in kN, acting on a corrugation is given by:

$$F_1 = s_1 \rho g \frac{(d_f - h_{DB} - h_{LS})^2}{2}$$

s_1, g, h_{DB}, h_{LS} = as given in 203

ρ = as given in 204 a)

d_f = as given in 202.

206 Resultant pressure and force - Homogeneous loading conditions

At each point of the bulkhead structures, the resultant pressure p , in kN/m^2 , to be considered for the scantlings of the bulkhead is given by:

$$p = p_{c,f} - 0.8 p_c$$

The resultant force F , in kN, acting on a corrugation is given by:

$$F = F_{c,f} - 0.8 F_c$$

207 Resultant pressure and force - Non-homogeneous loading conditions

At each point of the bulkhead structures, the resultant pressure p , in kN/m^2 , to be considered for the scantlings of the bulkhead is given by:

$$p = p_{c,f}$$

The resultant force F , in kN, acting on a corrugation is given by:

$$F = F_{c,f}$$

In case cargo hold no. 1, in non-homogeneous loading conditions, is not allowed to be loaded, the resultant pressure p , in kN/m^2 , to be considered for the scantlings of the bulkhead is given by:

$$p = p_f$$

and the resultant force F , in kN, acting on a corrugation is given by:

$$F = F_f$$

208 Bending moment in the bulkhead corrugation

The design bending moment M , in kNm , for the bulkhead corrugation is given by:

$$M = \frac{Fl}{8}$$

F = resultant force, in kN, as given in 206 or 207 as relevant

l = span of the corrugation, in m, to be taken according to Fig.2 and Fig.3.

209 Shear force in the bulkhead corrugation

The shear force Q , in kN, at the lower end of the bulkhead corrugations is given by:

$$Q = 0.8 F$$

F = as given in 208.

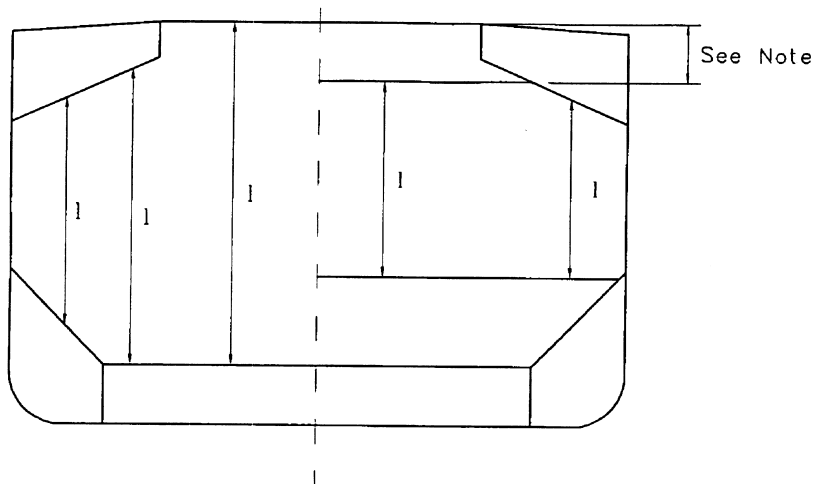

Note For the definition of l , the internal end of the upper stool is not to be taken more than a distance from the deck at the centre line equal to:

- 3 times the depth of corrugations, in general
- 2 times the depth of corrugations, for rectangular stool

Fig. 3
Definition of l

A 300 Strength criteria

301 General

The following criteria are applicable to transverse bulkheads with vertical corrugations (see Fig.2 and Fig.3). Where the corrugation angle ϕ shown in Fig.2 is less than 50° , an horizontal row of staggered shedder plates to be fitted at approximately mid depth of the corrugations (see Fig.2) to help preserve dimensional stability of the bulkhead under flooding loads. The shedder plates are to be welded to the corrugations by double continuous welding, but they are not to be welded to the side shell.

Requirements for local net plate thickness are given in 308.

In addition, the criteria as given in 302 and 305 are to be complied with.

The thickness of the lower part of corrugations considered in the application of 302 and 303 is to be maintained for a distance from the inner bottom, or the top of the lower stool not less than $0,15 l$.

The thickness of the middle part of corrugations as considered in the application of 302 and 304 is to be maintained to a distance from the deck, or the bottom of the upper stool not greater than $0,3 l$.

302 Bending capacity and shear stress τ

The bending capacity is to comply with the following relationship:

$$10^3 \frac{M}{0.5 Z_{le} \sigma_{a, le} + Z_m \sigma_{a, m}} \leq 1,0$$

M = bending moment, in kNm, as given in 208

Z_{le} = section modulus, in cm^3 , at the lower end of corrugations, to be calculated according to 303

Z_m = section modulus, in cm^3 , at the midspan of corrugations, to be calculated according to 304

$\sigma_{a, le}$ = allowable stress, in N/mm^2 , as given in 305, for the lower end of corrugations

$\sigma_{a, m}$ = allowable stress, in N/mm^2 , as given in 305, for the mid-span of corrugations.

In no case is Z_m to be taken greater than the lesser of $1.15 Z_{le}$

and $1.15 Z'_{le}$ for calculation of the bending capacity, Z'_{le} as being defined below.

In case shedder plates are fitted which:

- are not knuckled
- are welded to the corrugations and the top of the lower stool by one side penetration welds or equivalent
- are fitted with a minimum slope of 45° and their lower edge is in line with the stool side plating,

or gusset plates are fitted which:

- have a height not less than half of the flange width
- are fitted in line with the stool side plating
- have thickness and material properties at least equal to those provided for the flanges,

the section modulus Z_{le} , in cm^3 , is to be taken not larger than the value Z'_{le} , in cm^3 , given by:

$$Z'_{le} = Z_g + 10^3 \frac{Q h_g - 0.5 h_g^2 s_1 p_g}{\sigma_a}$$

Z_g = section modulus, in cm^3 , of the corrugations calculated, according to 304, in way of the upper end of shedder or gusset plates, as applicable

Q = shear force, in kN, as given in 209

h_g = height, in m, of shedders or gusset plates, as applicable (see Fig.4, Fig.5, Fig.6 and Fig.7)

s_1 = as given in 203

p_g = resultant pressure, in kN/m^2 , as defined in 206 or 207 as relevant calculated in way of the middle of the shedders or gusset plates, as applicable

σ_a = allowable stress, in N/mm^2 , as given in 305.

Stresses, τ , are obtained by dividing the shear force, Q , by the shear area. The shear area is to be reduced in order to account for possible non-perpendicularity between the corrugation webs and flanges. In general, the reduced shear area may be obtained by multiplying the web sectional area by $(\sin \phi)$, ϕ being the angle between the web and the flange.

When calculating the section modulus and the shear area, the net plate thickness is to be used.

The section modulus of corrugations are to be calculated on the bases of the following requirements given in 303 and 304.

303 Section modulus at the lower end of corrugations

The section modulus is to be calculated with the compression flange having an effective flange width, b_{ef} , not larger than as given in 306.

If the corrugation webs are not supported by local brackets below the stool top (or below the inner bottom) in the lower part, the section modulus of the corrugations is to be calculated considering the corrugation webs 30% effective.

- a) Provided that effective shedder plates, as defined in 302, are fitted (see Fig.4 and Fig.5), when calculating the section modulus of corrugations at the lower end (cross-section (1) in Fig.4 and Fig.5), the area of flange plates, in cm^2 , may be increased by:

$$\left(2.5 a \sqrt{t_f t_{sh}} \sqrt{\frac{\sigma_{Fsh}}{\sigma_{Ffl}}} \right)$$

(not to be taken greater than $2,5 a t_f$)

where:

- a = width, in m, of the corrugation flange (see Fig.2)
- t_{sh} = net shedder plate thickness, in mm
- t_f = net flange thickness, in mm.
- σ_{Fsh} = minimum upper yield stress, in n/mm^2 of the material used for the shedder plates
- σ_{Ffl} = minimum upper yield stress, in n/mm^2 of the material used for the corrugation flanges.

- b) Provided that effective gusset plates, as defined in 302, are fitted (see Fig.6 and Fig.7) when calculating the section modulus of corrugations at the lower end (cross-section (1) in Fig.6 and Fig.7), the area of flange plates, in cm^2 , may be increased by $(7 h_g t_{gu})$ where:

h_g = height of gusset plate in m, see Fig.6 and Fig.7, not to be taken greater than:

$$\left(\frac{10}{7} s_{gu} \right)$$

- s_{gu} = width of the gusset plates, in m
- t_f = net flange thickness, in mm, based on the as built condition.
- t_{gu} = net gusset plate thickness, in mm not to be taken greater than t_f

- c) If the corrugation webs are welded to a sloping stool top plate, which is at an angle not less than 45° with the horizontal plane, the section modulus of the corrugations may be calculated considering the corrugation webs fully effective. In case effective gusset plates are fitted, when calculating the section modulus of corrugations the area of flange plates may be increased as specified in b) above. No credit can be given to shedder plates only.

For angles less than 45° , the effectiveness of the web may be obtained by linear interpolation between 30% for 0° and 100% for 45° .

304 Section modulus of corrugations at cross-sections other than the lower end

The section modulus is to be calculated with the corrugation webs considered effective and the compression flange having an effective flange width, b_{ef} , not larger than as given in 306.

305 Allowable stress check

The normal and shear stresses σ and τ , are not to exceed the allowable values σ_a and τ_a , in N/mm^2 , given by:

$$\begin{aligned} \sigma_a &= \sigma_F \\ \tau_a &= 0.5 \sigma_F \end{aligned}$$

σ_F being the minimum upper yield stress, in N/mm^2 , of the material.

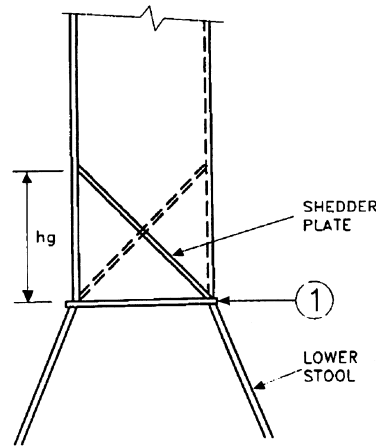

Fig. 4 Symmetric shedder plates

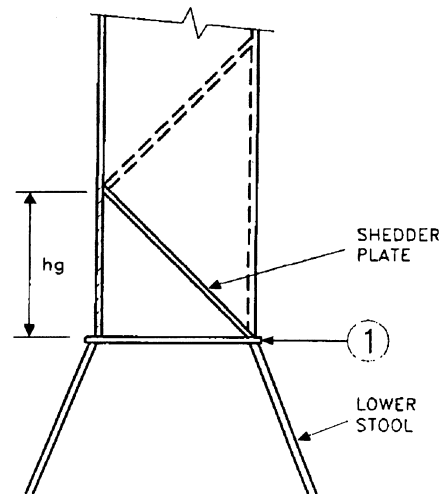

Fig. 5 Asymmetric shedder plates

306 Effective width of compression flange of corrugations

The effective width b_{ef} , in m, of the corrugation flange is given by:

$$b_{ef} = C_e a$$

where:

$$C_e = \frac{2.25}{\beta} - \frac{1.25}{\beta^2} \text{ for } \beta > 1.25$$

$$C_e = 1.0 \text{ for } \beta \leq 1.25$$

$$\beta = 10^3 \frac{a}{t_f} \sqrt{\frac{\sigma_F}{E}}$$

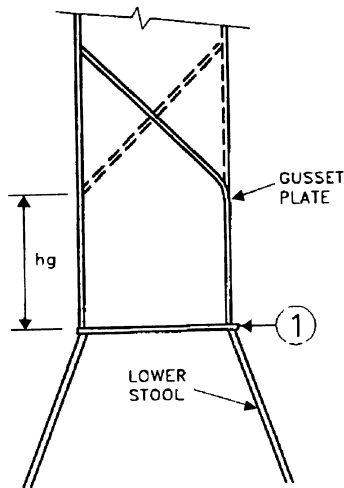

Fig. 6
Symmetric gusset or shedder plates

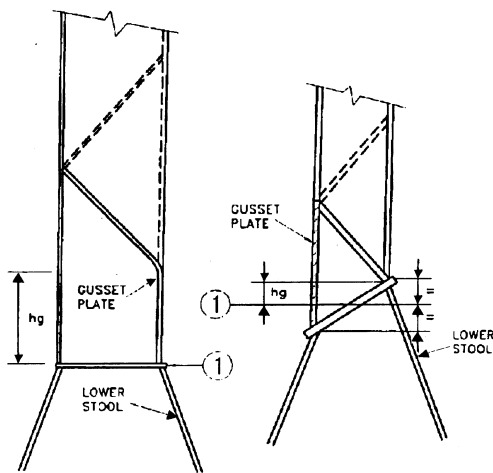

Fig. 7
Asymmetric gusset or shedder plates

- t_f = net flange thickness, in mm
 a = width, in m, of the corrugation flange (see Fig.2)
 σ_F = minimum upper yield stress, in N/mm², of the material
 E = modulus of elasticity of the material, in N/mm², to be assumed equal to $2.06 \cdot 10^5$ for steel.

307 Shear buckling

The buckling check is to be performed for the web plates at the corrugation ends.

The shear stress, τ , is not to exceed the critical value τ_c , in N/mm², as given in Pt.3 Ch.1 Sec.14, assuming a buckling factor $k_t = 6.34$ and net plate thickness as defined in this subsection.

308 Local net plate thickness

The bulkhead local net plate thickness t , in mm, is given by:

$$t = 14.9 s_w \sqrt{\frac{1.0p}{\sigma_F}}$$

- s_w = plate width, in m, to be taken equal to the width of the corrugation flange or web, whichever is the greater (see Fig.2)
 p = resultant pressure, in kN/m², as defined in 206 or 207

as relevant, at the bottom of each strake of plating. In all cases, the net thickness of the lowest strake is to be determined using the resultant pressure at the top of the lower stool, or at the inner bottom, if no lower stool is fitted or at the top of shedders, if shedder or gusset or shedder plates are fitted

σ_F = minimum upper yield stress, in N/mm² of the material.

For built-up corrugation bulkheads, when the thickness of the flange and web are different, the net thickness of the narrower plating is to be not less than t_n , in mm, given by:

$$t_n = 14.9 s_n \sqrt{\frac{1.0p}{\sigma_F}}$$

s_n being the width, in mm, of the narrower plating.

The net thickness of the wider plating, in mm, is not to be taken less than the maximum of the following values:

$$t_w = 14.9 s_w \sqrt{\frac{1.0p}{\sigma_F}}$$

and

$$t_w = \sqrt{\frac{440s_w^2 1.0p}{\sigma_F} - t_{np}^2}$$

t_{np} ≤ actual net thickness of the narrower plating and not to be greater than:

$$14.9 s_w \sqrt{\frac{1.0p}{\sigma_F}}$$

A 400 Local details

401 The design of local details, for the purpose of transferring the corrugated bulkhead forces and moments to the boundary structures, are to reflect local stress concentration due to abrupt change in stiffness. Areas of concern are in particular connection to double bottom, cross-deck structures and connection of stool construction (upper and lower) to top-wing and hopper tank construction.

The thickness and stiffening of effective gusset and shedder plates, as defined in 303, are to comply with Pt.3 Ch.1 Sec.9, based on the pressure load as given in 201 to 207.

Unless otherwise stated, weld connections and materials are to be dimensioned and selected in accordance with Pt.3 Ch.1.

A 500 Corrosion addition and steel renewal

501 Steel renewal is required where the gauged thickness is less than $t_{net} + 0.5$ mm, t_{net} being the thickness used for the calculation of bending capacity and shear stresses as given in 302 or the local net plate thickness as given in 308. Alternatively, reinforcing doubling strips may be used providing the net thickness is not dictated by shear strength requirements for web plates (see 305 and 307) or by local pressure requirements for web and flange plates (see 308).

Where the gauged thickness is within the range $t_{net} + 0.5$ mm and $t_{net} + 1.0$ mm, coating (applied in accordance with the coating manufacturer's requirements) or annual gauging may be adopted as an alternative to steel renewal.

502 Where steel renewal or reinforcement is required, a minimum thickness of $t_{net} + 2.5$ mm is to be replenished for the renewed or reinforced parts.

503 When:

$$0.8 (\sigma_{Ffl} t_{fl}) \geq \sigma_{FS} t_{st}$$

- σ_{Ffl} = minimum upper yield stress, in N/mm², of the material used for the corrugation flanges
 σ_{FS} = minimum upper yield stress, in N/mm², of the material

used for the lower stool side plating or floors (if no stool is fitted)

t_{fl} = flange thickness, in mm, which is found to be acceptable based on the criteria specified in 501 above or, when steel renewal is required, the replenished thickness according to the criteria specified in 502 above. The above flange thickness dictated by local pressure requirements (see 308) need not be considered for this purpose

t_{st} = as built thickness, in mm, of the lower stool side plating or floors (if no stool is fitted).

Gussets with shedder plates, extending from the lower end of corrugations up to $0.1 l$, or reinforcing doubling strips (on bulkhead corrugations and stool side plating) are to be fitted.

If gusset plates are fitted, the material of such gusset plates is to be the same as that of the corrugation flanges. The gusset plates are to be connected to the lower stool shelf plate or inner bottom (if no lower stool is fitted) by deep penetration welds (see Fig.8).

504 Where steel renewal is required, the bulkhead connections to the lower stool shelf plate or inner bottom (if no stool is fitted) are to be at least made by deep penetration welds (see Fig.8).

505 Where gusset plates are to be fitted or renewed, their connections with the corrugations and the lower stool shelf plate or inner bottom (if no stool is fitted) are to be at least made by deep penetration welds (see Fig.8).

B. Existing Bulk Carriers - Limit to Hold Loading considering Hold Flooding

B 100 Application and definition

101 These requirements apply to the double bottom structure of cargo hold no. 1 for all bulk carriers of 150 m in length and above, in the foremost hold, subject to mandatory class notation **Bulk Carrier ESP**, intending to carry solid bulk cargoes having a density of 1.78 t/m^3 or above with single deck, top-side tanks and hopper tanks. Where:

- i) the foremost hold is bounded by the side shell only for ships which were contracted for construction prior to 1 July 1998, and have not been constructed in compliance with IACS Unified Requirement S20.
- ii) the foremost hold is double side skin construction of less than 760 mm breadth measured perpendicular to side shell in ships, the keel of which were laid, or which were at a similar stage of construction, before 1 July 1999 and have not been constructed in compliance with IACS Unified Requirement S20. (Rev.2, Sept. 2000)

The requirements shall, at the latest, be complied with as follows:

- i) for ships which were 20 years of age or more on 1 July 1998, by the due date of the first intermediate, or the due date of the first renewal survey to be held after 1 July 1998, whichever comes first;
- ii) for ships which were 15 years of age or more but less than 20 years of age on 1 July 1998, by the due date of the first renewal survey to be held after 1 July 1998, but not later than 1 July 2002;
- iii) for ships which were 10 years of age or more but less than 15 years of age on 1 July 1998, by the due date of the first intermediate or the first renewal survey to be held after the

date on which the ship reaches 15 years of age but not later than the date on which the ship reaches 17 years of age;

- iv) for ships which were 5 years of age or more but less than 10 years of age on 1 July 1998, by the due date, after 1 July 2003, of the first intermediate or first renewal survey after the date on which the ship reaches 10 years of age, whichever occurs first;

- v) for ships which were less than 5 years of age on 1 July 1998, by the date on which the ship reaches 10 years of age.

The loading in cargo hold no. 1 is not to exceed the limit to hold loading in flooded condition, calculated as per 401, using the loads given in 201 and 202 and the shear capacity of the double bottom given in 301 to 303.

In no case is the loading in each cargo hold to exceed design hold loading in intact condition.

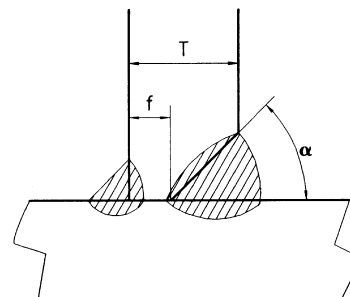
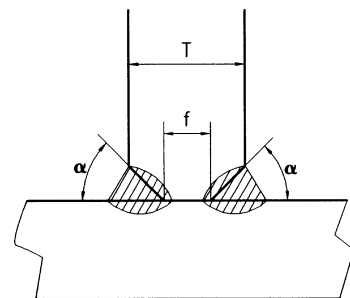

Root Face (f) : 3 mm to T/3 mm
Groove Angle (α) : 40° to 60°

Fig. 8
Deep penetration welds

B 200 Load model

201 General

The loads to be considered as acting on the double bottom of cargo hold no.1 are those given by the external sea pressures and the combination of the cargo loads with those induced by the flooding of cargo hold no.1.

The most severe combinations of cargo induced loads and flooding loads are to be used, depending on the loading conditions included in the loading manual:

- homogeneous loading conditions
- non-homogeneous loading conditions
- packed cargo conditions (such as steel mill products).

For each loading condition, the maximum bulk cargo density to be carried is to be considered in calculating the allowable hold loading limit.

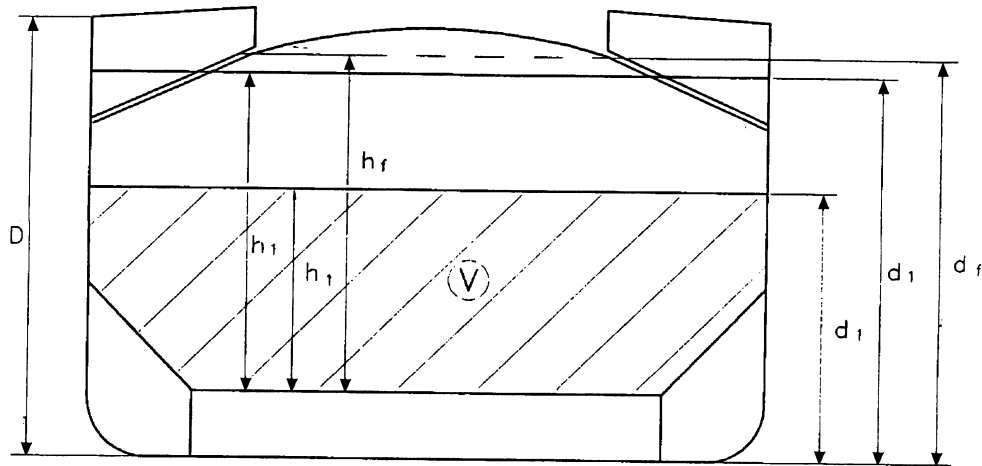

V = Volume of cargo

Fig. 9
Definition of flooding head and D

202 Inner bottom flooding head

The flooding head h_f (see Fig.9) is the distance, in m, measured vertically with the ship in the upright position, from the inner bottom to a level located at a distance d_f , in m, from the baseline equal to:

- a) in general:
 - D for the foremost cargo hold
- b) for ships less than 50 000 tonnes deadweight with Type B freeboard:
 - 0.95 D for the foremost cargo hold

D being the distance, in m, from the baseline to the freeboard deck at side amidships (see Fig.9).

B 300 Shear capacity

301 Shear capacity of the double bottom

The shear capacity, C, of the double bottom of cargo hold no.1 is defined as the sum of the shear strength at each end of:

- all floors adjacent to both hoppers, less one half of the strength of the two floors adjacent to each stool, or transverse bulkhead if no stool is fitted (see Fig.10)
- all double bottom girders adjacent to both stools, or transverse bulkheads if not stool is fitted.

The strength of girders or floors which run out and are not directly attached to the boundary stool or hopper girder is to be evaluated for the one end only.

Note that the floors and girders to be considered are those inside the cargo hold boundaries formed by the hoppers and stools (or transverse bulkheads if no stool is fitted). The hopper side girders and the floors directly below the connection of the bulkhead stools (or transverse bulkheads if no stool is fitted) to the inner bottom are not to be included.

When the geometry and/or the structural arrangement of the double bottom are such to make the above assumptions inadequate,

the shear capacity C of double bottom will be subject to special consideration.

In calculating the shear strength, the net thickness of floors and girders is to be used. The net thickness t_{net} , in mm, is given by:

$$t_{net} = t - 2.0$$

t = thickness, in mm, of floors and girders.

302 Floor shear strength

The floor shear strength in way of the floor panel adjacent to hoppers S_{f1} , in kN, and the floor shear strength in way of the openings in the outmost bay (i.e. that bay which is closer to hopper) S_{f2} , in kN, are given by the following expressions:

$$S_{f1} = 10^{-3} A_f \frac{\tau_a}{\eta_1}$$

$$S_{f2} = 10^{-3} A_{f,h} \frac{\tau_a}{\eta_2}$$

A_f = sectional area, in mm^2 , of the floor panel adjacent to hoppers

$A_{f,h}$ = net sectional area, in mm^2 , of the floor panels in way of the openings in the outmost bay (i.e. that bay which is closer to hopper)

τ_a = the allowable shear stress, in N/mm^2 , to be taken equal to:

$$\frac{\sigma_F}{\sqrt{3}}$$

σ_F = minimum upper yield stress, in N/mm^2 , of the material

η_1 = 1.10

η_2 = 1.20

η_2 may be reduced to 1.10 when appropriate reinforcements are fitted around openings.

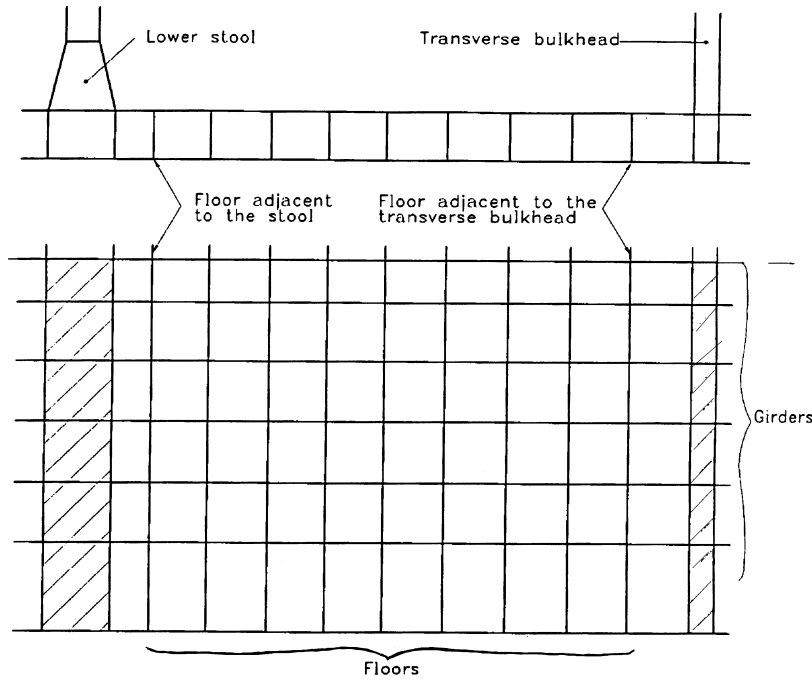

Fig. 10
Arrangement of double bottom

303 Girder shear strength

The girder shear strength in way of the girder panel adjacent to stools (or transverse bulkheads, if no stool is fitted) S_{g1} , in kN, and the girder shear strength in way of the largest opening in the outmost bay (i.e. that bay which is closer to stool, or transverse bulkhead, if no stool is fitted) S_{g2} , in kN, are given by the following expressions:

$$S_{g1} = 10^{-3} A_g \frac{\tau_a}{\eta_1}$$

$$S_{g2} = 10^{-3} A_{g,h} \frac{\tau_a}{\eta_2}$$

where:

- A_g = minimum sectional area, in mm^2 , of the girder panel adjacent to stools (or transverse bulkheads, if no stool is fitted)
- $A_{g,h}$ = net sectional area, in mm^2 , of the girder panel in way of the largest opening in the outmost bay (i.e. that bay which is closer to stool, or transverse bulkhead, if no stool is fitted)
- τ_a = allowable shear stress, in N/mm^2 , as given in 302
- η_1 = 1.10
- η_2 = 1.15

η_2 may be reduced to 1.10 when appropriate reinforcements are fitted around openings.

B 400 Limit to cargo hold loading, considering flooding

401 The limit to cargo hold loading, W , in tonnes, is given by:

$$W = \rho_c V \frac{1}{F}$$

- F = 1.1 in general
- = 1.05 for steel mill products
- ρ_c = bulk cargo density, in t/m^3 (see 201).
- V = volume, in m^3 , occupied by cargo at a level h_1

$$h_1 = \frac{X}{\rho_c g}$$

X = the lesser of X_1 and X_2 given by

$$X_1 = \frac{Z + \rho g (E - h_f)}{1 + \frac{\rho}{\rho_c} (\text{perm} - 1)}$$

$$X_2 = Z + \rho g (E - h_f \text{ perm})$$

- ρ = sea water density, in t/m^3
- g = $9.81 \text{ m}/\text{s}^2$, gravity acceleration
- E = ship immersion in m for flooded hold condition
- = $d_f - 0.1 D$
- d_f, D = as given in 202
- h_f = flooding head, in m, as defined in 202
- Z = the lesser of Z_1 and Z_2 given by:

$$Z_1 = \frac{C_h}{A_{DB,h}}$$

$$Z_2 = \frac{C_e}{A_{DB,e}}$$

C_h = shear capacity of the double bottom, in kN, as defined in 301, considering, for each floor, the lesser of the shear strengths S_{f1} and S_{f2} (see 302) and, for each girder, the lesser of the shear strengths S_{g1} and S_{g2} (see 303)

C_e = shear capacity of double bottom, in kN, as defined in 301, considering, for each floor, the shear strength S_{f1} (see 302) and, for each girder, the lesser of the shear strengths S_{g1} and S_{g2} (see 303)

$$A_{DH,h} = \sum_{i=1}^{i=n} S_i B_{DB,i}$$

$$A_{DB,c} = \sum_{i=1}^{i=n} S_i(B_{DB} - s_l)$$

- n = number of floors between stools (or transverse bulkheads, if no stool is fitted)
 S_i = space of i th-floor, in m
 $B_{DB,i}$ = $B_{DB} - s_l$ for floors whose shear strength is given by S_{fl} (see 302)
 $B_{DB,i}$ = $B_{DB,h}$ for floors whose shear strength is given by S_{f2} (see 302)
 B_{DB} = breadth of double bottom, in m, between hoppers (see Fig.11)
 $B_{DB,h}$ = distance, in m, between the two considered opening (see Fig.11)
 s_l = spacing, in m, of double bottom longitudinals adjacent to hoppers

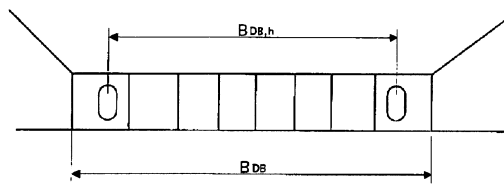

Fig. 11
Dimensions of double bottom

C. Existing Bulk Carriers - Damage Stability

C 100 Application

101 Vessels subject to rule requirements in subsections E and F shall, when loaded to the summer load line, be able to withstand flooding of the foremost cargo hold in all loading conditions and remain afloat in a satisfactory condition of equilibrium as specified in 102.

102 The condition of equilibrium after flooding shall satisfy the condition of equilibrium laid down in the annex to resolution A.320(IX) - Regulation equivalent to regulation 27 of the International Convention on Load Lines, 1966, as amended by resolution A.514(13). The assumed flooding need take into account flooding of the cargo hold space only. The permeability of the loaded hold shall be assumed as 0.9 and the permeability of an empty cargo hold shall be assumed as 0.95, unless a permeability relevant to a particular cargo is assumed for the volume of a flooded hold occupied by cargo and a permeability of 0.95 is assumed for the remaining empty volume of the hold.

103 Bulk carriers which have been assigned a reduced freeboard in compliance with the provisions of regulation 27(8) of the annex to resolution A.320(IX), as amended by resolution A.514(13) may be considered as complying with requirements as given in 101.

104 Vessels not satisfying the requirements given in 101 or 103 are to be provided with detailed information on specific cargo hold flooding scenarios. This information shall be accompanied by detailed instructions on evacuation preparedness under the provisions of Section 8 of the International Safety Management (ISM) Code and be used as the basis for crew training and drills. (SOLAS reg. XII/9.3).

D. Existing Bulk Carriers - Loading Information

D 100 Loading computer system

101 All vessels with one of the following class notations are

to be provided with an approved loading computer system:

Bulk Carrier ESP

Ore Carrier ESP

Bulk Carrier or Tanker for Oil ESP

Ore Carrier or Tanker for Oil ESP.

This is applicable for vessels of 150 m in length (L) and above, that were contracted for construction before 1 July 1998. The loading computer system is to be installed, in approved order, not later than their entry into service or 1 January 1999, whichever occurs later.

102 The loading computer system is to be of a multipoint type and be able to easily and quickly ascertain that, at specified read-out points, the still water bending moment, shear forces and still water torsional and lateral loads, where applicable, in any load or ballast condition will not exceed the specified permissible values.

D 200 Loading sequences

201 All single side skin vessels with class notation:

Bulk Carrier ESP

of 150 m in length (L) and above, that were contracted for construction before 1 July 1998 are to be provided, before 1 July 1999 or their entry into service, whichever occurs later, with an approved loading manual with typical loading and unloading sequences. The loading sequences should describe the loading from commencement of cargo loading to reaching full deadweight capacity, for homogenous conditions, relevant part-load conditions and alternate conditions where applicable.

E. Existing Bulk Carriers – Detection of Water Ingress into Cargo Holds

E 100 Application and definition

101 The requirements in E apply to vessels subject to the requirements in C, but which do not satisfy either C101 or C103 due to having been constructed with an insufficient number of transverse watertight bulkheads.

102 The requirements shall be complied with as follows:

- i) for ships that were 20 years of age or more on 1 July 1998, by the due date of the first intermediate, or the due date of first complete periodical survey to be held after 1 July 1998, whichever comes first;
- ii) for ships that were 15 years of age or more but less than 20 years of age on 1 July 1998, by due date of the first complete periodical survey to be held after 1 July 1998, but not later than 1 July 2002;
- iii) for ships that were 10 years of age or more but less than 15 years of age on 1 July 1998, by the due date of the next complete periodical survey after the date on which the ship reaches 15 years of age but not later than the date on which the ship reaches 17 years of age; and
- iv) for ships that were less than 10 years of age on 1 July 1998, by the date on which the ship reaches 15 years of age.

(IACS UR S23.1)

However, ships that have already passed their due date are to comply not later than the first intermediate or the first complete periodical survey.

E 200 Detection of water ingress

201 The vessel shall be provided with an approved bilge well high water level alarm in all cargo holds, or in cargo conveyor tunnels, as appropriate, giving an audible and visual alarm on the navigation bridge.

(SOLAS reg. XII/9.2)

202 In addition, the vessel is to be provided with an approved permanent means of detecting the presence of water in the cargo holds, in excess of the small amounts which may be normally expected in the bilge wells.

(IACS UR S24.2)

E 300 Means of water ingress detection

301 The method of detection is to be by direct means. A direct means is one where the presence of water is detected by physical contact of the water with the measuring device. Examples of direct means are pressure sensitive tape and individual liquid actuated switches.

302 The bilge well high water level alarm and water ingress detectors are to actuate audible and visual alarms in a permanently manned space when water has reached the pre-set detection level for the cargo hold (see 306). When the alarm is actuated, the cargo hold affected should be identifiable on a control panel in the permanently manned space.

303 A water ingress detector is to be fitted in the aft part of each cargo hold or in cargo conveyor tunnels, as appropriate.

304 An interlocking device may be installed in the water detection system for the floodable cargo hold.

305 Detectors, such as pressure sensitive tapes, are to be installed in tubes or similarly protected locations to protect them from mechanical damage and to isolate them from the cargo.

306 Water ingress detectors are to be arranged to detect water when it reaches a level 2 metres above the inner bottom.

(IACS UR S24.3)

E 400 Installation, testing and survey

401 The system is to be installed and tested in accordance with the manufacturer's specifications. At the initial installation and at each subsequent complete periodical survey the surveyor is to verify the proper operation of the water detection system.

(IACS UR S24.5).

F. Existing Ice Class ICE-1A and ICE-1A* - Minimum Power Requirement

F 100 General

101 For general information and definitions, see Pt.5 Ch.1 Sec.3 J101, J102 and J103, respectively.

F 200 Application

201 For assignment of ice class notation **ICE-1A** or **ICE-1A*** a ship shall comply with the new power requirements in 300.

F 300 Existing ships

301 To be entitled to ice class **ICE-1A** or **ICE-1A*** a ship the keel of which is laid or which is at a similar stage of construction before 1 September 2003 shall comply with the requirements in Pt.5 Ch.1 Sec.3 J104 or the alternative requirements in 302 by:

- 1 January 2005
- 1 January in the year when 20 years has elapsed since the year the ship was delivered, whichever occurs the latest.

302 When, for an existing ship, values for some of the hull parameters required for the calculating method in Pt.5 Ch.1 Sec.3 J104 are difficult to obtain, then the following alternative formulae can be used:

$$R_{CH} = C_1 + C_2 + C_3(H_F + H_M)^2(B + 0.658H_F) + C_4LH_F^2 + C_5\left(\frac{LT}{B^2}\right)^3\frac{B}{4} \quad (N)$$

For ice class **ICE-1A**, C_1 and C_2 can be taken as zero. For ice class **ICE-1A***, ship without bulb, the following apply:

$$C_1 = f_1\frac{BL}{\frac{T}{2} + 1} + 1.84(f_2B + f_3L + f_4BL)$$

$$C_2 = 3.52(g_1 + g_2B) + g_3\left(1 + 1.2\frac{T}{B}\right)\frac{B^2}{\sqrt{L}}$$

For ice class **ICE-1A***, ship with bulb, C_1 and C_2 shall be calculated as follows:

$$C_1 = f_1\frac{BL}{\frac{T}{2} + 1} + 2.89(f_2B + f_3L + f_4BL)$$

$$C_2 = 6.67(g_1 + g_2B) + g_3\left(1 + 1.2\frac{T}{B}\right)\frac{B^2}{\sqrt{L}}$$

- $f_1 = 10,3 \text{ N/m}^2$
- $f_2 = 45,8 \text{ N/m}$
- $f_3 = 2,94 \text{ N/m}$
- $f_4 = 5,8 \text{ N/m}^2$
- $g_1 = 1530 \text{ N}$
- $g_2 = 170 \text{ N/m}$
- $g_3 = 400 \text{ N/m}^{1,5}$
- $C_3 = 460 \text{ kg/(m}^2\text{s}^2)$
- $C_4 = 18,7 \text{ kg/(m}^2\text{s}^2)$
- $C_5 = 825 \text{ kg/s}^2$

The following shall apply:

$$20 \geq \left(\frac{LT}{B^2}\right)^3 \geq 5$$

303 The Society may, by permission of the maritime administration of Sweden and Finland, grant an existing ship its original ice class even if it does not comply with the requirements in 301 and 302. This is provided the ship has regularly called at ports in the respective country, in the winter season and on the condition that the experience of the performance of the ship in ice, has been satisfactory to the administration in question.

304 Other methods of determining K_e or R_{CH}

The Society may for an individual ship, in lieu of the K_e or R_{CH} values defined above, approve the use of K_e values based on more exact calculations or R_{CH} values based on model tests. Such an approval will be given on the understanding that it can be revoked if experience of the ship's performance in practice motivates this.